

► 蜗轮减速机系列

Worm gear reducer

产品介绍

PRODUCTS GUIDE 3-29

结构图及型号表示法
STRUCTURAL DRAWINGS & TYPE
EXPRESSIONS 6

单级标准系列

SINGLE STANDARD SERIES 7-13

双级WPE系列

DOUBLE WPE SERIES 14-21

万能型减速机

UNIVERSAL SPEED REDUCER 22-29

输入轴功率及出力轴力矩表

INPUT POWER & OUTPUT TORQUE 30-32

减速机选型方法

REDUCER SELECTION METHODS 33-36

安装与使用

INSTALL AND USAGE 36

润滑油的选择使用

CHOICE OF LUBRICANTS 37

故障原因及解决办法

SOLUTIONS AND REASONS FOR THE
GENERAL FAULTS 38



产品介绍 PRODUCTS GUIDE

单级减速机
SINGLE SPEED REDUCER
速比1/5-1/60



WPA	WPDA	WPKA	WPDKA
WPS	WPD	WPKS	WPDKS
WPO	WPDO	WPZ	WPDZ
WPX	WPDX	WPKZ	WPDKZ

双级减速机
DOUBLE SPEED REDUCER
速比1/100-1/3600



WPEA	WPEDA	WPEKA	WPEKA
WPES	WPEDS	WPEKS	WPEDKS
WPEO	WPEDO	WPWEDO	WPWEO
WPEX	WPEDX	WPWEKO	WPWEDKO
WPWE	WPWED	WPWEK	WPWEDK

产品介绍 PRODUCTS GUIDE

万能型减速机
UNIVERSAL SPEED REDUCER

速比1/5-1/60



	WPW	WPWD	WPWK	WPWDK
	WPWA	WPWDA	WPWKA	WPWDKA
	WPWS	WPWDS	WPWKS	WPWDKS
	WPWO	WPWDO	WPWKO	WPWDKO
	WPWX	WPWDX	WPWKT	WPWDKT
	WPWT	WPWDT	WPWKV	WPWDKV
	WPWV	WPWDV		
	WRST	WRSTD		
			AS TV OX 	

蜗轮减速机产品结构图

PRODUCT STRUCTURAL DRAWING OF WORM GEAR SPEED REDUCER

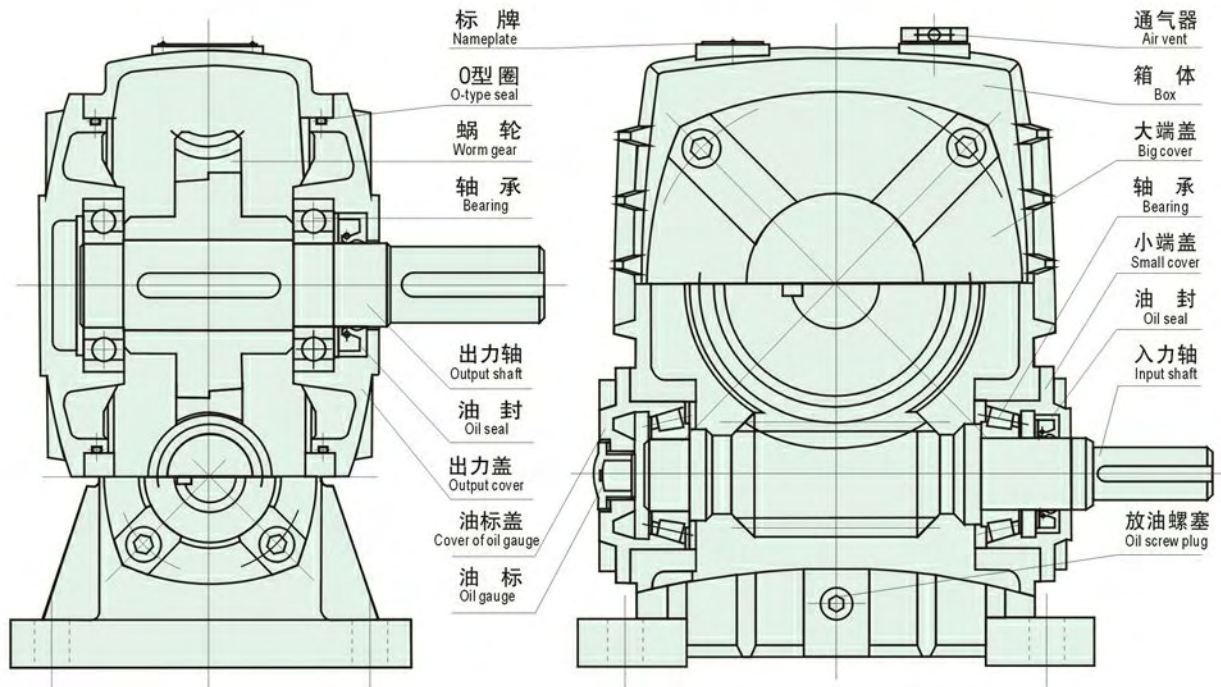

减速机型号及表示法

TYPE & EXPRESSIONS

W P W E D K A 40-250 — 1/5-1/900 — B

■ 公司简称
W—
Company Abbreviation
W—

■ 箱体结构
P-整体
D-分体
Box structure
P-whole
D-separate

■ W-万能型
W-universal

■ E-双级
EE-多级
E-Double
EE-Multistage

■ D-入轴带电机法兰
D-Input shaft with
motor frange

■ K-中孔结构
K-Hollow Structure

■ A--入轴在下 S--入轴在上
O--出轴向上 X--出轴向下
T--入轴向上 V--入轴向下
A-Input shaft is below
S-Input shaft is above
O-Output shaft is upward
X-Output shaft is downward
T-Input shaft is upward
V-Input shaft is downward

■ 40-250--中心距
40-250--Center
distance

■ 1/10-1/+900--减速比
1/10-1/+900--Ratio

■ B--出轴指向
B--Output shaft
direction

WPA

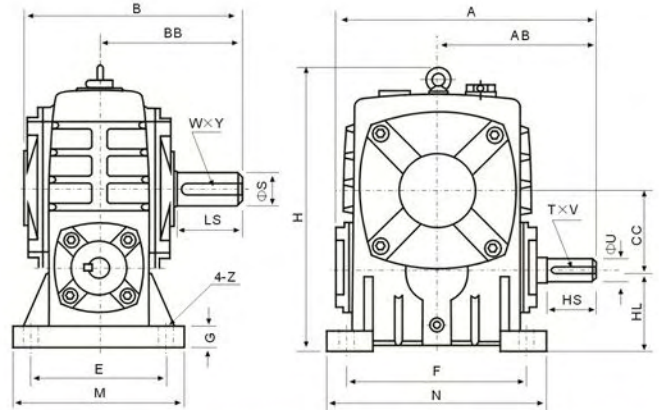

轴指向表示
SHAFT DIRECTION

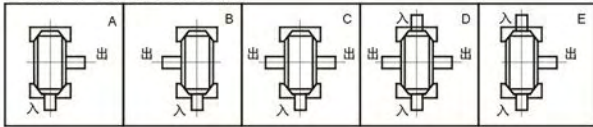

型号 size	减速比 ratio	A	AB	B	BB	CC	H	HL	M	N	E	F	G	Z	输入轴input shaft			输出轴output shaft			重量 (kg)	油量 (L)
															HS	U	T×V	LS	S	W×Y		
40		143	87	114	74	40	138	40	90	100	70	80	13	10	25	12	4×2.5	28	14	5×3	4	0.13
50		175	108	150	97	50	176	50	120	140	95	110	15	12	30	12	4×2.5	40	17	5×3	7	0.17
60	1/5	198	120	168	112	60	204	60	130	150	105	120	20	12	40	15	5×3	50	22	7×4	10	0.22
70	1/10	231	140	194	131	70	236	70	150	190	115	150	20	15	40	18	5×3	60	28	7×4	15	0.60
80	1/15	261	160	214	142	80	268	80	170	220	135	180	20	15	50	22	7×4	65	32	10×4.5	20	0.85
100	1/20	322	190	254	169	100	336	100	190	270	155	220	25	15	50	25	7×4	75	38	10×4.5	35	1.50
120	1/25	371	219	282	190	120	430	120	230	320	180	260	30	18	65	30	7×4	85	45	12×4.5	60	3.20
135	1/30	422	249	317	210	135	480	135	250	350	200	290	30	18	75	35	10×4.5	95	55	16×6	80	3.60
147	1/40	432	256	320	210	147	460	123	250	350	200	280	32	18	75	35	10×4.5	95	55	16×6	98	3.70
155	1/50	497	295	382	252	155	531	135	275	390	220	320	35	21	85	40	12×5	110	60	18×7	110	3.80
175	1/60	534	314	388	255	175	600	160	310	430	250	350	40	21	85	45	14×5.5	110	65	18×7	150	4.60
200		580	342	456	319	200	666	175	360	480	290	390	40	24	95	50	14×5.5	125	70	20×7.5	215	6.50
250		703	420	552	385	250	800	200	460	560	380	480	45	28	110	60	18×7	155	90	25×9	360	9.00

WPS

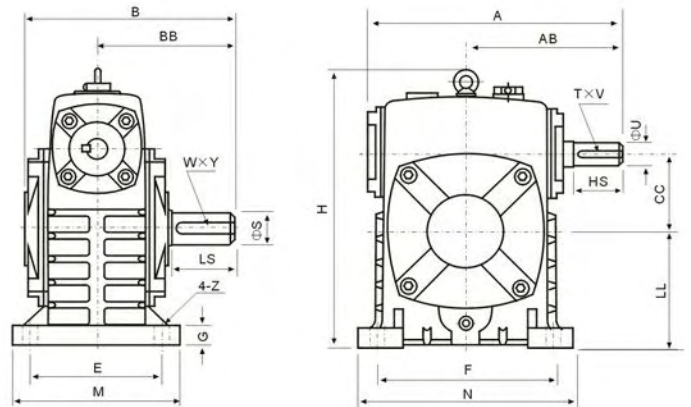

轴指向表示
SHAFT DIRECTION

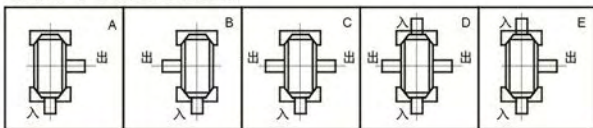

型号 size	减速比 ratio	A	AB	B	BB	CC	H	LL	M	N	E	F	G	Z	输入轴input shaft			输出轴output shaft			重量 (kg)	油量 (L)
															HS	U	T×V	LS	S	W×Y		
40		143	87	114	74	40	141	60	90	100	70	80	13	10	25	12	4×2.5	28	14	5×3	4	0.30
50		175	108	150	97	50	180	80	120	140	95	110	15	12	30	12	4×2.5	40	17	5×3	7	0.45
60	1/5	198	120	168	112	60	207	90	130	150	105	120	20	12	40	15	5×3	50	22	7×4	10	0.55
70	1/10	231	140	194	131	70	238	105	150	190	115	150	20	15	40	18	5×3	60	28	7×4	15	0.80
80	1/15	261	160	214	142	80	273	120	170	220	135	180	20	15	50	22	7×4	65	32	10×4.5	20	1.10
100	1/20	322	190	254	169	100	334	150	190	270	155	220	25	15	50	25	7×4	75	38	10×4.5	35	2.90
120	1/25	371	219	282	190	120	423	180	230	320	180	260	30	18	65	30	7×4	85	45	12×4.5	60	4.40
135	1/30	422	249	317	210	135	482	215	250	350	200	290	30	18	75	35	10×4.5	95	55	16×6	80	6.20
147	1/40	432	256	320	210	147	460	203	250	350	200	280	32	18	75	35	10×4.5	95	55	10×6	98	3.70
155	1/50	497	295	382	252	155	541	235	275	390	220	320	35	21	85	40	12×5	110	60	18×7	110	6.50
175	1/60	534	314	388	255	175	600	260	310	430	250	350	40	21	85	45	14×5.5	110	65	18×7	150	8.00
200		580	342	456	319	200	677	290	360	480	290	390	40	24	95	50	14×5.5	125	70	20×7.5	215	9.30
250		703	420	552	385	250	824	350	460	560	380	480	45	28	110	60	18×7	155	90	25×9	360	18.0

WPX



WPX轴指向表示
SHAFT DIRECTION

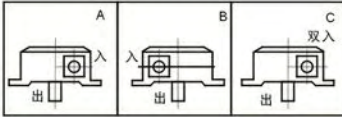

WPO



WPO轴指向表示
SHAFT DIRECTION

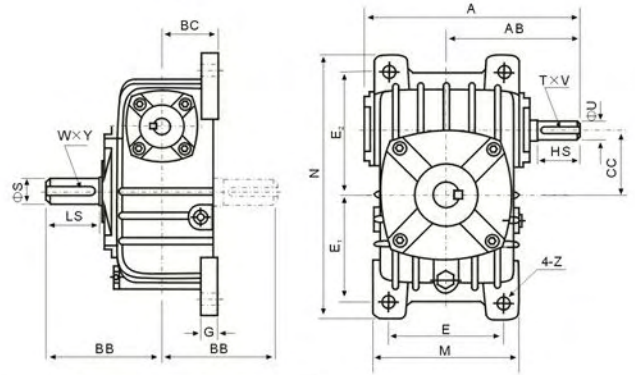
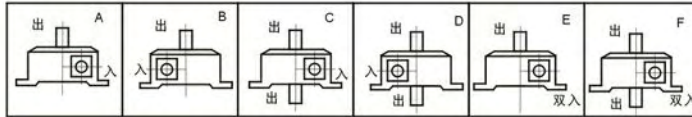

型号 size	减速比 ratio	A	AB	BB	BC	CC	M	N	E	E ₁	E ₂	G	Z	入力轴input shaft			出力轴output shaft			重量 (kg)	油量 (L)
														HS	U	T×V	LS	S	W×Y		
40	1/5	143	87	74	45	40	94	184	70	74	86	10	10	25	12	4×2.5	28	14	5×3	5	0.36
50		175	108	97	50	50	116	220	90	93	102	15	12	30	12	4×2.5	40	17	5×3	6	0.50
60	1/10	198	120	112	55	60	126	260	100	105	120	20	12	40	15	5×3	50	22	7×4	10	0.60
70		231	140	131	65	70	156	295	120	120	135	20	15	40	18	5×3	60	28	7×4	15	1.10
80	1/15	261	160	142	70	80	175	320	140	130	150	20	15	50	22	7×4	65	32	10×4.5	20	1.50
100		322	190	169	90	100	224	375	190	155	180	26	15	50	25	7×4	75	38	10×4.5	35	4.00
120	1/20	371	219	190	100	120	286	450	220	185	215	30	18	65	30	7×4	85	45	12×4.5	50	5.20
135		422	249	210	110	135	306	495	260	210	235	30	18	75	35	10×4.5	95	55	16×6	75	7.50
147	1/40	432	256	210	114	147	302	558	250	230	278	32	18	75	35	10×4.5	95	55	16×6	96	8.50
155		497	295	252	140	155	350	590	290	245	295	35	21	85	40	12×5	110	60	18×7	115	9.30
175	1/60	534	314	255	150	175	394	640	320	267	323	40	21	85	45	14×5.5	110	65	18×7	140	10.5
200		580	342	319	175	200	440	710	370	290	360	40	24	95	50	14×5.5	125	70	20×7.5	200	12.7
250		705	420	385	200	250	510	860	440	350	440	45	28	110	60	18×7	155	90	25×9	340	23.0

WPDA



轴指向表示
SHAFT DIRECTION

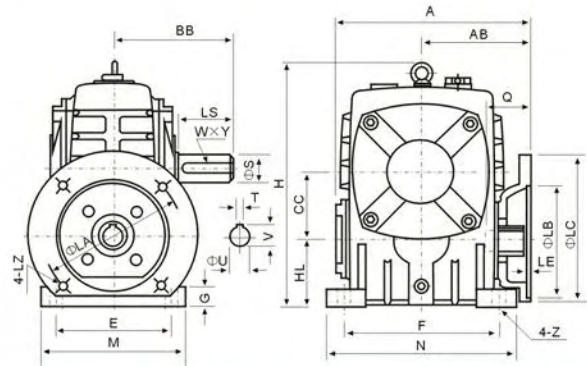
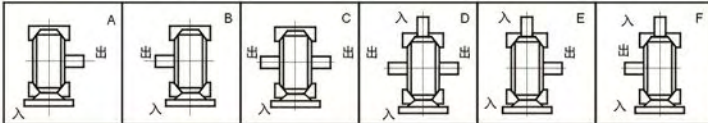

型号 size	入功率 (kw)	减速比 ratio	A	AB	BB	CC	H	HL	M	N	E	F	G	Z	电机法兰flange					入力孔input hole			出力轴output shaft			重量 (kg)
															LA	LB	LC	LE	LZ	Q	U	T×V	LS	S	W×Y	
40	0.12	1/5	135	75	74	40	138	40	90	100	70	80	13	10	115	95	140	4	M8	31	11	4×12.8	28	14	5×3	5
50	0.18		151	83	97	50	176	50	120	140	95	110	15	12	115	95	140	4	M8	31	11	4×12.8	40	17	5×3	8
60	0.37	1/10	167	91	112	60	204	60	130	150	105	120	20	12	130	110	160	4	M8	33	14	5×16.3	50	22	7×4	11
70	0.37 0.75		200	109	111	131	70	236	70	150	190	115	150	20	15	130	110	160	4	M8	40	14	5×16.3 8×27.3	60	28	7×4
80	0.75 1.5	1/15	225	125	142	80	268	80	170	220	135	180	20	15	165	130	200	4.5	M10	48	19	6×21.8	65	32	10×4.5	22
100	1.5 2.2		280	148	169	100	336	100	190	270	155	220	25	15	165	130	200	4.5	M10	52	24	8×27.3				
120	3.0 1/25	1/20	333	181	190	120	430	120	230	320	180	260	30	18	215	180	250	5	M12	63	28	8×31.3	85	45	12×4.5	64
135	3.0 4.0		375	202	210	135	480	135	250	350	200	290	30	18	215	180	250	5	M12	63	28	8×31.3	95	55	16×6	85
147	3.0 4.0	1/40	415	235	210	147	460	123	250	350	200	280	32	18	215	180	250	5	M12	63	28	8×31.3	95	55	16×6	105
155	5.5 1/50		448	247	252	155	531	135	275	390	220	320	35	21	265	230	300	5	M12	83	38	10×41.3	110	60	18×7	118
175	5.5 7.5	1/60	481	262	255	175	600	160	310	430	250	350	40	21	265	230	300	5	M12	83	38	10×41.3	110	65	18×7	165
200	11.0		543	285	319	200	666	175	360	480	290	390	40	24	300	250	350	6	M16	114	42	12×45.3	125	70	20×7.5	236
250	11.0 15.0		615	330	385	250	800	200	460	560	380	480	45	28	300	250	350	6	M16	114	42	12×45.3	155	90	25×9	396

WPDS



轴指向表示
SHAFT DIRECTION

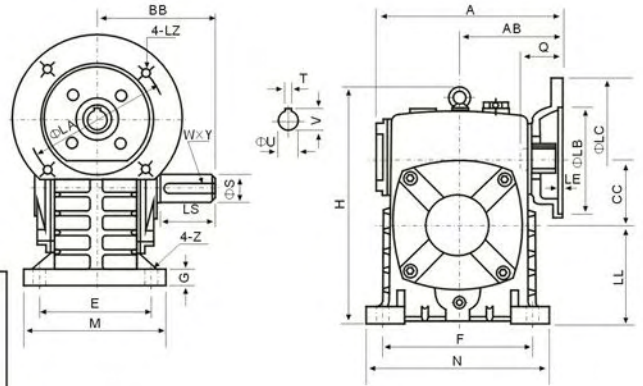
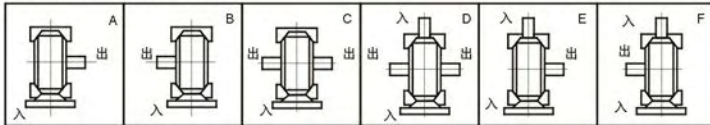

型号 size	入功率 (kw)	减速比 ratio	电机法兰flange											入力孔Input hole			出力轴output shaft			重量 (kg)						
			A	AB	BB	CC	H	LL	M	N	E	F	G	Z	LA	LB	LC	LE	LZ		Q	U	T×V	LS	S	W×Y
40	0.12	1/5 1/10 1/15 1/20 1/25 1/30 1/40 1/50 1/60	135	75	74	40	141	60	90	100	70	80	13	10	115	95	140	4	M8	31	11	4×12.8	28	14	5×3	5
50	0.18		151	83	97	50	176	80	120	140	95	110	15	12	115	95	140	4	M8	31	11	4×12.8	40	17	5×3	8
60	0.37		167	91	112	60	202	90	130	150	105	120	20	12	130	110	160	4	M8	33	14	5×16.3	50	22	7×4	11
70	0.37		200	109	131	70	238	105	150	190	115	150	20	15	130	110	160	4	M8	40	14	5×16.3	60	28	7×4	17
	0.75		165	130											200	M10	42		19	6×21.8						
80	0.75		225	125	142	80	273	120	170	220	135	180	20	15	165	130	200	4.5	M10	48	19	6×21.8	65	32	10×4.5	22
	1.5		52	24	8×27.3																					
100	1.5		280	148	169	100	334	150	190	270	155	220	25	15	165	130	200	4.5	M10	52	24	8×27.3	75	38	10×4.5	38
120	2.2		333	181	190	120	423	180	230	320	180	260	30	18	215	180	250	5	M12	63	28	8×31.3	85	45	12×4.5	64
	3.0																									
135	3.0		375	202	210	135	482	215	250	350	200	290	30	18	215	180	250	5	M12	63	28	8×31.3	95	55	16×6	85
	4.0																									
155	5.5		448	247	252	155	541	235	275	390	220	320	35	21	265	230	300	5	M12	83	38	10×41.3	110	60	18×7	118
	5.5																									
175	7.5		481	262	255	175	600	260	310	430	250	350	40	21	265	230	300	5	M12	83	38	10×41.3	110	65	18×7	165
	5.5																									
200	11.0	543	285	319	200	677	290	360	480	290	390	40	24	300	250	350	6	M16	114	42	12×45.3	125	70	20×7.5	236	
250	11.0	615	330	385	250	824	350	460	560	380	480	45	28	300	250	350	6	M16	114	42	12×45.3	155	90	25×9	396	
	15.0																									

WPDX



WPDX轴指向表示
SHAFT DIRECTION

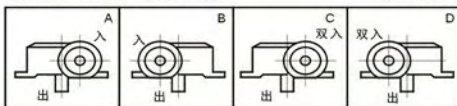

WPDO



WPDO轴指向表示
SHAFT DIRECTION

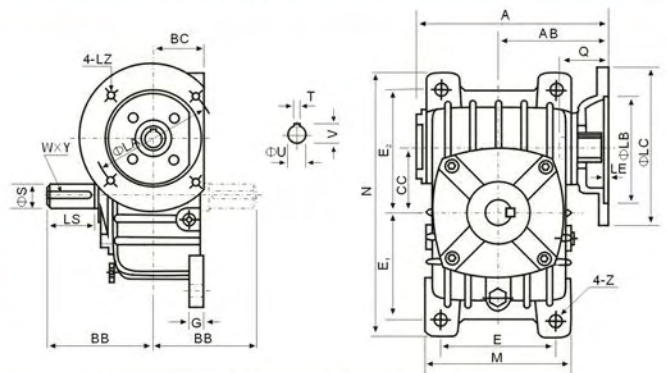
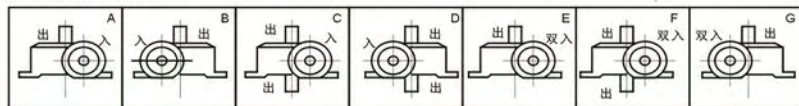

型号 size	入功率 (kw)	减速比 ratio	电机法兰flange											入力孔Input hole			出力轴output shaft			重量 (kg)						
			A	AB	BB	BC	CC	M	N	E	E ₁	E ₂	G	Z	LA	LB	LC	LE	LZ		Q	U	T×V	LS	S	W×Y
40	0.12	1/5 1/10 1/15 1/20 1/25 1/30 1/40 1/50 1/60	135	75	74	45	40	94	184	70	74	86	10	10	115	95	140	4	M8	31	11	4×12.8	28	14	5×3	5
50	0.18		151	83	97	50	50	116	220	90	93	102	15	12	115	95	140	4	M8	31	11	4×12.8	40	17	5×3	8
60	0.37		167	91	112	55	60	126	260	100	105	120	20	12	130	110	160	4	M8	33	14	5×16.3	50	22	7×4	11
70	0.37		200	109	131	65	70	156	295	120	120	135	20	15	130	110	160	4	M8	40	14	5×16.3	60	28	7×4	17
	0.75		165	130											200	M10	42		19	6×21.8						
80	0.75		225	125	142	70	80	175	320	140	130	150	20	15	165	130	200	4.5	M10	48	19	6×21.8	65	32	10×4.5	22
	1.5		52	24	8×27.3																					
100	1.5		280	148	169	90	100	224	375	190	155	180	25	15	165	130	200	4.5	M10	52	24	8×27.3	75	38	10×4.5	38
120	2.2		333	181	190	100	120	266	450	220	185	215	30	18	215	180	250	5	M12	63	28	8×31.3	85	45	12×4.5	64
	3.0																									
135	3.0		375	202	210	110	135	306	495	260	210	235	30	18	215	180	250	5	M12	63	28	8×31.3	95	55	16×6	85
	4.0																									
147	3.0		415	235	210	114	147	302	558	250	254	254	32	18	215	180	250	5	M12	63	28	8×31.3	95	55	16×6	105
	4.0																									
155	5.5		448	247	252	140	155	350	590	290	245	295	35	21	265	230	300	5	M12	83	38	10×41.3	110	60	18×7	118
	5.5																									
175	7.5	481	262	255	150	175	394	640	320	267	323	40	21	265	230	300	5	M12	83	38	10×41.3	110	65	18×7	165	
	5.5																									
200	11.0	543	285	319	175	200	440	710	370	290	360	40	24	300	250	350	6	M16	114	42	12×45.3	125	70	20×7.5	236	
250	11.0	615	330	385	200	250	510	860	440	350	440	45	28	300	250	350	6	M16	114	42	12×45.3	155	90	25×9	396	
	15.0																									

WPKA

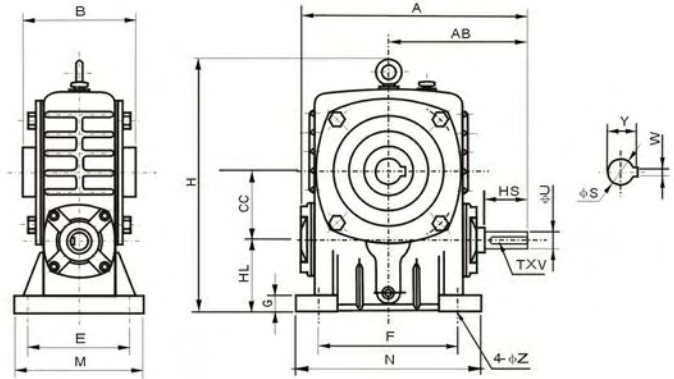

轴指向表示
SHAFT DIRECTION

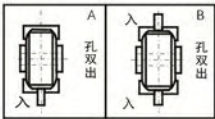

型号 size	传动比 ratio	A	AB	B	CC	H	HL	M	N	E	F	G	Z	入力轴 input hole			出力轴 output shaft		重量 (kg)
														HS	U	T×V	S	W×Y	
40	1/5	143	87	85	40	138	40	90	100	70	80	13	10	25	12	4×2.5	16	6×18.8	5
50		175	108	105	50	176	50	120	140	95	110	15	11	30	12	4×2.5	20	6×22.8	7.5
60	1/10	198	120	110	60	204	60	130	150	105	120	20	11	40	15	5×3	25	8×28.3	11
70	1/15	231	140	130	70	236	70	150	190	115	150	20	15	40	18	5×3	30	8×33.3	15.5
80	1/20	261	160	150	80	268	80	170	220	135	180	20	15	50	22	7×4	35	10×38.3	22
100	1/25	322	190	160	100	336	100	190	270	155	220	25	15	60	25	7×4	40	12×43.3	36
120	1/30	371	219	175	120	430	120	230	320	180	260	30	18	65	30	7×4	45	14×48.8	62
135	1/40	422	249	210	135	480	135	250	350	200	290	30	18	75	35	10×4.5	60	18×64.4	80
147	1/50	438	262	210	147	460	123	250	350	200	280	32	18	75	35	10×4.5	65	18×64.4	90
155	1/60	497	295	256	155	531	135	275	390	220	320	35	20	85	40	12×5	70	20×74.9	114
175		534	314	282	175	600	160	310	430	250	350	40	20	85	45	14×5.5	80	22×85.4	150
200	1/60	580	342	320	200	666	175	360	480	290	390	40	22	95	50	14×5.5	85	22×90.4	215
250		705	420	400	250	800	200	460	560	380	480	45	28	110	60	18×7	110	28×90	360

WPKS

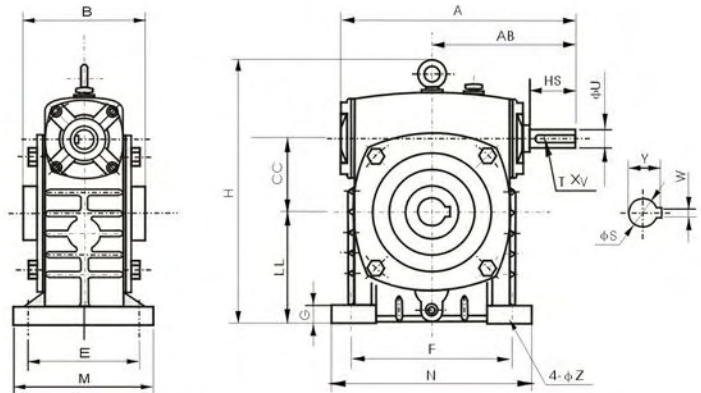

轴指向表示
SHAFT DIRECTION

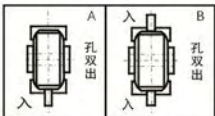

型号 size	传动比 ratio	A	AB	B	CC	H	LL	M	N	E	F	G	Z	入力轴 input hole			出力轴 output shaft		重量 (kg)
														HS	U	T×V	S	W×Y	
40	1/5	143	87	85	40	141	60	90	100	70	80	13	10	25	12	4×2.5	16	6×18.8	4
50		175	108	105	50	180	80	120	140	75	110	15	11	35	12	4×2.5	20	6×22.8	7
60	1/10	198	120	110	60	207	90	130	150	105	120	20	11	40	15	5×3	25	8×28.3	10.5
70	1/15	231	140	130	70	238	105	150	190	115	150	25	15	40	18	5×3	30	8×33.3	14.5
80	1/20	261	160	150	80	270	120	170	220	135	180	25	15	50	22	7×4	35	10×38.3	22
100	1/25	322	190	160	100	331	150	190	260	155	220	25	15	60	25	7×4	40	12×43.3	36
120	1/30	371	219	175	120	423	180	230	320	180	260	30	18	65	30	7×4	45	14×48.8	63
135	1/40	422	249	200	135	482	215	250	350	200	290	30	18	75	35	10×4.5	60	18×64.4	80
155	1/50	497	295	256	155	495	235	280	390	220	320	38	20	85	40	12×5	70	20×74.9	114
175	1/60	534	314	282	175	541	260	310	430	250	350	40	20	85	45	14×5.5	80	22×85.4	150
200		580	342	320	200	594	290	360	480	290	390	42	22	95	50	14×5.5	85	22×90.4	218
250	705	420	400	250	800	350	460	560	380	480	45	28	110	60	18×7	110	28×90	365	

WPZ

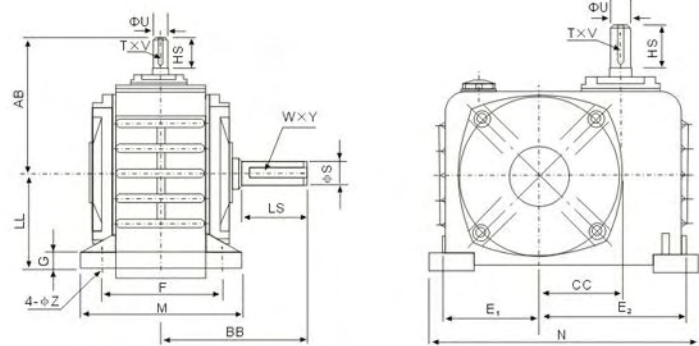

轴指向表示
SHAFT DIRECTION

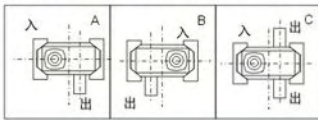

型号 size	减速比 ratio	AB	LL	B	BB	CC	E ₁	E ₂	F	G	M	N	Z	入力孔Input hole			出力轴output shaft			重量 (kg)	油量 (L)
														HS	U	T×V	LS	S	W×Y		
50	1/5	108	77	150	97	50	53	77	100	15	125	160	11	30	12	4×2.5	40	17	5×3	7	0.4
60	1/10	120	82	168	112	60	68	92	100	15	130	190	11	40	15	5×3	50	22	7×4	10	0.5
70	1/15	140	95	194	131	70	75	115	120	20	155	230	15	40	18	5×3	60	28	7×4	15	0.6
80	1/20	160	100	214	142	80	96	144	125	20	160	265	15	50	22	7×4	65	32	10×4.5	20	1.1
100	1/30	190	135	254	169	100	100	150	155	22	196	310	15	50	25	7×4	75	38	10×4.5	35	1.5
120	1/40	219	160	282	190	120	120	180	180	28	230	360	18	65	30	7×4	85	45	12×4.5	60	4
135	1/50	249	170	317	210	135	130	200	200	30	250	410	18	75	35	10×4.5	95	55	16×6	80	5.2

WPKZ

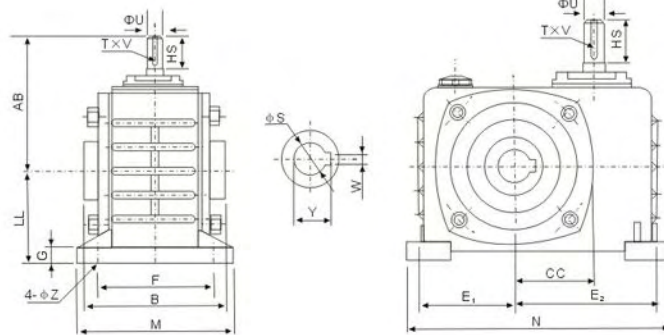

型号 size	减速比 ratio	AB	LL	B	CC	E ₁	E ₂	F	G	M	N	Z	入力孔Input hole			出力轴output shaft		重量 (kg)	油量 (L)
													HS	U	T×V	S	W×Y		
50	1/5	108	77	150	50	53	77	100	15	125	160	11	30	12	4×2.5	20	6×22.8	7	0.4
60	1/10	120	82	168	60	68	92	100	15	130	190	11	40	15	5×3	25	8×28.3	10	0.5
70	1/15	140	95	194	70	75	115	120	20	155	230	15	40	18	5×3	30	8×28.3	15	0.6
80	1/20	160	100	214	80	96	144	125	20	160	265	15	50	22	7×4	35	10×38.3	20	1.1
100	1/30	190	135	254	100	100	150	155	22	196	310	15	50	25	7×4	40	12×43.3	35	1.5
120	1/40	219	160	282	120	120	180	180	28	230	360	18	65	30	7×4	45	14×48.8	60	4
135	1/50	249	170	317	135	130	200	200	30	250	410	18	75	35	10×4.5	60	18×64.4	80	5.2

WPDKA

轴指向表示
SHAFT DIRECTION

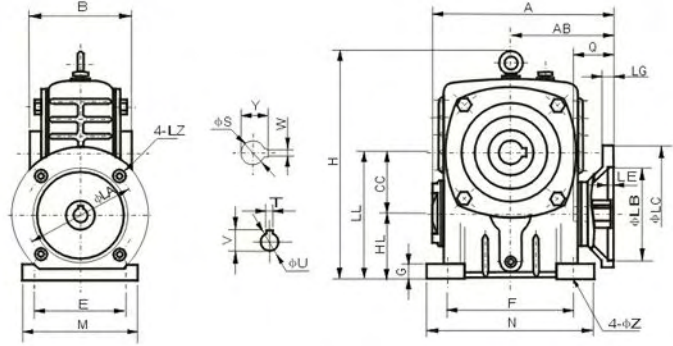
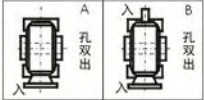

型号 Size	入功率 (kw)	传动比 ratio	A	AB	B	CC	H	HL	M	N	E	F	G	Z	电机法兰flange					入力孔Input hole			出力孔Output shaft		重量 (kg)
															LA	LB	LC	LE	LZ	Q	U	T×V	S	W×Y	
40	0.12	1/5 1/10 1/15 1/20 1/25 1/30 1/40 1/50 1/60	135	75	85	40	138	40	90	100	70	80	13	11	115	95	140	4	M8	31	11	4×12.8	16	6×18.8	5
50	0.18		151	83	105	50	176	50	120	140	95	110	15	11	115	95	140	4	M8	31	11	4×12.8	20	6×22.8	8
60	0.37		167	91	110	60	204	60	130	150	105	120	20	11	130	110	160	4	M8	33	14	5×16.3	25	8×28.3	10.5
70	0.37		200	109	130	70	236	70	150	190	115	150	20	15	130	110	160	4	M8	40	14	5×16.3	30	8×33.3	17
	0.75		202	111											165	130	200		M10	42	19	6×21.8			
80	0.75		225	125	150	80	268	80	170	220	135	180	20	15	165	130	200	4.5	M10	48	19	6×21.8	35	10×38.3	25
	1.5		52	24	8×27.3																				
100	1.5		280	148	160	100	336	100	190	270	155	220	25	15	165	130	200	4.5	M10	52	24	8×27.3	40	12×43.3	38
	2.2		333	181	175	120	430	120	230	320	180	260	30	18	215	180	250	5	M12	63	28	8×31.3	45	14×48.8	60
120	3.0		375	202	210	135	480	135	250	350	200	290	30	18	215	180	250	5	M12	63	28	8×31.3	60	18×64.4	85
	4.0																								
135	4.0		425	224	256	155	531	135	275	390	220	320	35	20	215	180	250	5	M12	63	28	8×31.3	70	20×74.9	120
	5.5	448	247	265											230	300	5	M12	83	38	10×41.3				
155	5.5	481	262	282	175	600	160	310	430	250	350	40	20	265	230	300	5	M12	83	38	10×41.3	80	22×85.4	150	
	7.5	516	258	320	200	666	175	360	480	290	390	40	22	265	230	300	6	M12	83	38	10×41.3	85	22×90.4	218	
11.0	543	285	300											250	350	M16		114	42	12×45.3					
175	7.5	615	330	400	250	800	200	460	560	380	480	45	27	300	250	350	6	M16	114	42	12×45.3	110	28×116.4	350	
	15.0																								

WPDKS

轴指向表示
SHAFT DIRECTION

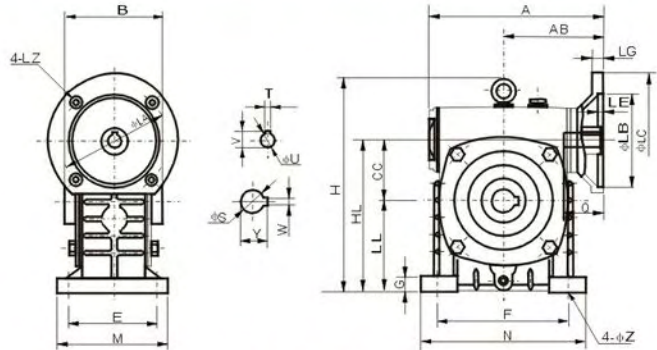

型号 Size	入功率 (kw)	传动比 ratio	A	AB	B	CC	H	LL	M	N	E	F	G	Z	电机法兰flange					入力孔Input hole			出力孔Output shaft		重量 (kg)
															LA	LB	LC	LE	LZ	Q	U	T×V	S	W×Y	
40	0.12	1/5 1/10 1/15 1/20 1/25 1/30 1/40 1/50 1/60	135	75	85	40	138	60	90	100	70	80	13	10	115	95	140	4	M8	31	11	4×12.8	16	6×18.8	5
50	0.18		151	83	105	50	180	80	120	140	95	110	15	11	115	95	140	4	M8	31	11	4×12.8	20	6×22.8	8
60	0.37		167	91	110	60	207	90	130	150	105	120	20	11	130	110	160	4	M8	33	14	5×16.3	25	8×28.3	10.5
70	0.37		200	109	130	70	238	105	150	190	115	150	20	15	130	110	160	4	M8	40	14	5×16.3	30	8×33.3	17
	0.75		202	111											165	130	200		M10	42	19	6×21.8			
80	0.75		225	125	150	80	273	120	170	220	135	180	20	15	165	130	200	4.5	M10	48	19	6×21.8	35	10×38.3	25
	1.5		52	24	8×27.3																				
100	1.5		280	148	160	100	334	150	190	270	155	220	25	15	165	130	200	4.5	M10	52	24	8×27.3	40	12×43.3	38
	2.2		333	181	175	120	423	180	230	320	180	260	30	18	215	180	250	5	M12	63	28	8×31.3	45	14×48.8	60
120	3.0		375	202	210	135	482	215	250	350	200	290	30	18	215	180	250	5	M12	63	28	8×31.3	60	18×64.4	85
	4.0																								
135	4.0		425	224	256	155	541	235	275	390	220	320	35	20	215	180	250	5	M12	63	28	8×31.3	70	20×74.9	120
	5.5	448	247	265											230	300	5	M12	83	38	10×41.3				
155	5.5	481	262	282	175	600	260	310	430	250	350	40	20	265	230	300	5	M12	83	38	10×41.3	80	22×85.4	150	
	7.5	516	258	320	200	677	290	360	480	290	390	40	22	265	230	300	5	M12	83	38	10×41.3	85	22×90.4	218	
11.0	543	285	300											250	350	M16		114	42	12×45.3					
175	7.5	615	330	400	250	824	350	460	560	380	480	45	27	300	250	350	6	M16	114	42	12×45.3	110	28×116.4	350	
	15.0																								

WPDZ

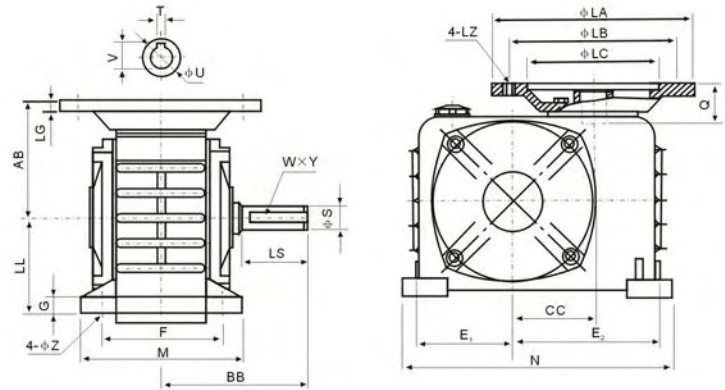

轴指向表示
SHAFT DIRECTION

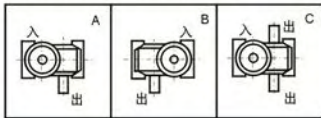

型号 size	入功率 (kw)	减速比 ratio	电机法兰flange											入力孔input hole			出力轴output shaft			重量 (kg)					
			AB	LL	BB	CC	E ₁	E ₂	F	G	M	N	Z	LB	LC	LA	LG	LZ	Q		U	T×V	LS	S	W×Y
50	0.18	1/5	88	77	97	50	53	77	100	15	125	160	11	115	95	140	10	M8	26	11	4×12.8	40	17	5×3	8
60	0.18		80	82	112	60	68	92	100	15	130	190	11	115	95	140	10	M8	27	11	4×12.8	50	22	7×4	12.5
70	0.37	1/10	100	95	131	70	75	115	120	20	155	230	15	130	110	160	10	M8	32	14	5×16.3	60	28	7×4	16
	0.75	1/15																	42	19	6×21.8				
80	0.75	1/20	120	100	142	80	96	144	125	20	160	265	15	165	130	200	12	M10	45	19	6×21.8	65	32	10×4.5	23
	1.5	1/25																	57	24	8×27.3				
100	1.5	1/30	150	135	169	100	100	150	155	22	195	310	15	165	130	200	15	M10	60	24	8×27.3	75	38	10×4.5	38
	3.0	1/40																	70	28	8×31.3				
120	2.2	1/50	165	160	190	120	120	180	180	28	230	360	18	215	180	250	18	M12	70	28	8×31.3	85	45	12×4.5	60
	3.0	1/60																	28	28	8×31.3				
135	3.0	4.0	185	170	210	135	130	200	200	30	250	390	18	215	180	250	20	M12	68	28	8×31.3	95	55	16×6	80
	4.0																		28	28	8×31.3				

WPDKZ

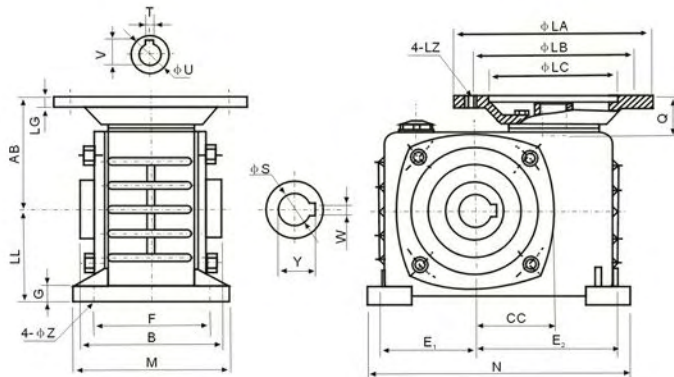

型号 size	入功率 (kw)	减速比 ratio	电机法兰flange											入力孔input hole			出力轴output shaft		重量 (kg)					
			AB	B	CC	E ₁	E ₂	F	G	LL	N	M	Z	LB	LC	LA	LG	LZ		Q	U	T×V	S	W×Y
50	0.18	1/5	88	105	50	53	77	100	15	77	160	125	11	115	95	140	10	M8	26	11	4×12.8	20	6×22.8	8
60	0.18		80	110	60	68	92	100	15	82	190	130	11	115	95	140	10	M8	27	11	4×12.8	25	8×28.3	12.5
70	0.37	1/10	100	130	70	75	115	120	20	95	230	155	15	130	110	160	10	M8	32	14	5×16.3	30	8×33.3	16
	0.75	1/15																	42	19	6×21.8			
80	0.75	1/20	120	150	80	96	144	125	20	100	265	160	15	165	130	200	12	M10	45	19	6×21.8	35	10×38.3	23
	1.5	1/25																	57	24	8×27.3			
100	1.5	1/30	150	160	100	100	150	155	22	135	310	195	15	165	130	200	15	M10	60	24	8×27.3	40	12×43.3	38
	3.0	1/40																	70	28	8×31.3			
120	2.2	1/50	165	175	120	120	180	180	28	160	360	230	18	215	180	250	18	M12	70	28	8×31.3	45	14×48.8	60
	3.0	1/60																	28	28	8×31.3			
135	3.0	4.0	185	210	135	130	200	200	30	170	390	250	18	215	180	250	20	M12	68	28	8×31.3	60	18×64.4	80
	4.0																		28	28	8×31.3			

WPEA

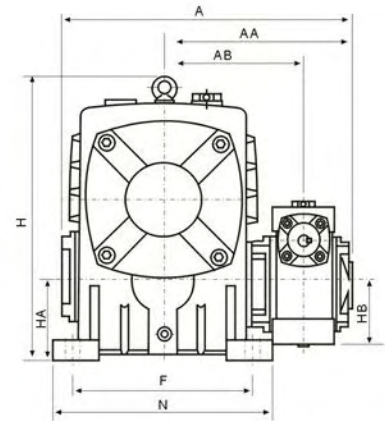
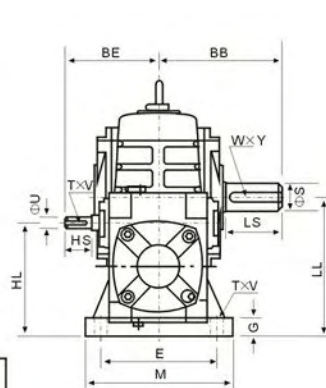

轴指向表示
SHAFT DIRECTION

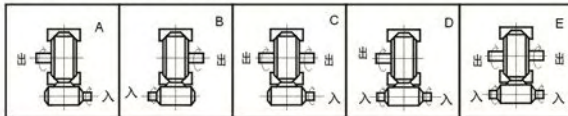

型号 size	减速比 ratio	A	AA	AB	BB	BE	HL	LL	H	HA	HB	M	N	E	F	G	Z	入力孔input hole				出力轴output shaft			重量 (kg)
																		HS	U	T×V	LS	S	W×Y		
40-70	1/200	286	195	153	131	87	110	140	236	70	50	150	190	115	150	20	15	25	12	4×2.5	60	28	7×4	20	
50-80	1/300	297	197	144	142	108	130	160	268	80	65	170	220	135	180	20	15	30	12	4×2.5	65	32	10×4.5	27	
60-100	1/400	363	231	175	169	120	160	200	336	100	75	190	270	155	220	25	15	40	15	5×3	75	38	10×4.5	44	
70-120	1/500	408	256	193	190	140	190	240	430	120	90	230	320	180	260	30	18	40	18	5×3	85	45	12×4.5	73	
80-135	1/600	471	298	226	210	160	215	270	480	135	105	250	350	200	290	30	18	50	22	7×4	95	55	16×6	101	
100-155	1/800	555	354	269	252	190	235	290	531	135	130	275	390	220	320	35	21	50	25	7×4	110	60	18×7	144	
120-175	1/900	598	379	287	255	219	280	335	600	160	155	310	430	250	350	40	21	65	30	7×4	110	65	18×7	201	
135-200	662	425	318	319	256	310	375	666	175	185	360	480	290	390	40	24	75	35	10×5	125	70	20×7.5	293	
155-250	795	510	380	385	295	355	450	800	200	203	460	560	380	480	45	28	85	40	12×5	155	90	25×9	462	

WPES

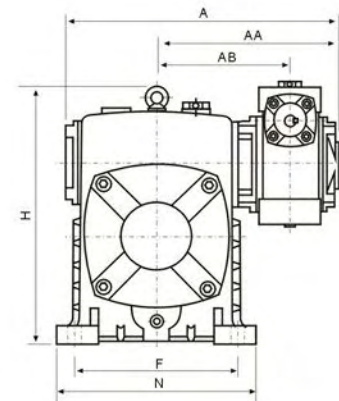
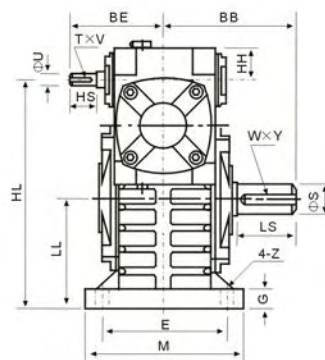

轴指向表示
SHAFT DIRECTION

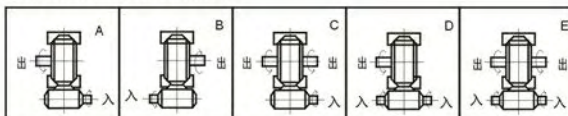

型号 size	传动比 ratio	A	AA	AB	BB	BE	HL	LL	H	HH	M	N	E	F	G	Z	入力孔input hole				出力轴output shaft			重量 (kg)
																	HS	U	T×V	LS	S	W×Y		
40-70	1/200	286	195	153	131	87	215	105	238	35	150	190	115	150	20	15	25	12	4×2.5	60	28	7×4	20	
50-80	1/300	297	197	144	142	108	250	120	273	35	170	220	135	180	20	15	30	12	4×2.5	65	32	10×4.5	27	
60-100	1/400	363	231	175	169	120	310	150	334	42	190	270	155	220	25	15	40	15	5×3	75	38	10×4.5	44	
70-120	1/500	408	256	193	190	140	370	180	423	55	230	320	180	260	30	18	40	18	5×3	85	45	12×4.5	73	
80-135	1/600	471	298	226	210	160	430	215	482	65	250	350	200	290	30	18	50	22	7×4	95	55	16×6	101	
100-155	1/800	555	354	269	252	190	490	235	541	80	275	390	220	320	35	21	50	25	7×4	110	60	18×7	144	
120-175	1/900	598	379	287	255	219	555	260	600	95	310	430	250	350	40	21	65	30	7×4	110	65	18×7	201	
135-200	662	425	318	319	256	625	290	677	105	360	480	290	390	40	24	75	35	10×4.5	125	70	20×7.5	293	
155-250	795	510	380	385	205	755	350	824	103	460	560	380	480	45	28	85	40	12×5	155	90	25×9	462	

WPEO



WPEX

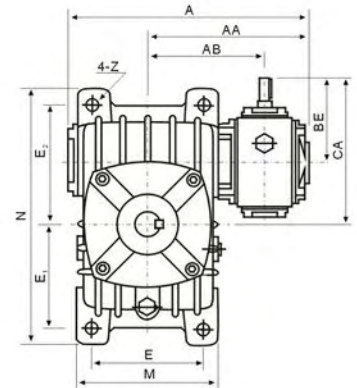
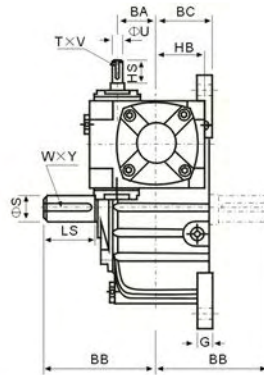

WPEO轴指向表示
SHAFT DIRECTION

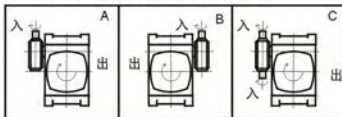

WPEX轴指向表示
SHAFT DIRECTION

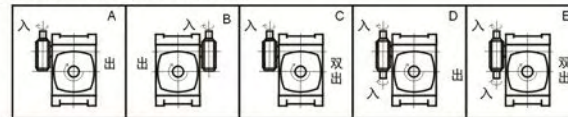

型号 size	减速比 ratio	A	AA	AB	BA	BB	BC	BE	HB	CA	M	N	E	E ₁	E ₂	G	Z	入力轴			出力轴			重量 (kg)
																		HS	U	T×V	LS	S	W×Y	
40-70	1/200	286	195	153	40	131	65	87	50	157	156	295	120	120	135	20	15	25	12	4×2.5	60	28	8×4	19
50-80	1/300	297	197	144	50	142	70	108	65	188	175	320	140	130	150	20	15	30	12	4×2.5	65	32	10×4.5	27
60-100	1/400	363	231	175	60	169	90	120	75	222	224	375	190	155	180	26	15	40	15	5×3	75	38	10×4.5	44
70-120	1/500	408	256	193	70	190	100	140	90	260	266	450	220	185	215	30	18	40	18	5×3	85	45	12×4.5	63
80-135	1/600	471	298	226	80	210	110	160	105	295	306	495	260	210	235	30	18	50	22	7×4	95	55	16×6	96
100-155	1/800	555	354	269	100	252	140	190	130	345	350	590	290	245	295	35	21	50	25	7×4	110	60	18×7	149
120-175	1/900	598	379	287	120	255	150	219	155	394	394	640	320	267	323	40	21	65	30	7×4	110	65	18×7	191
135-200	662	425	318	135	319	175	256	185	456	440	710	370	290	360	40	24	75	35	10×4.5	125	70	20×7.5	278
155-250	795	510	380	155	385	200	295	203	545	510	860	440	350	440	45	28	85	40	12×5	155	90	25×9	442

WPWE

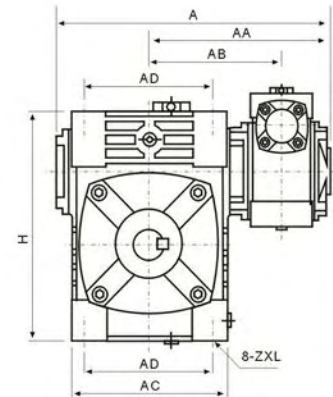
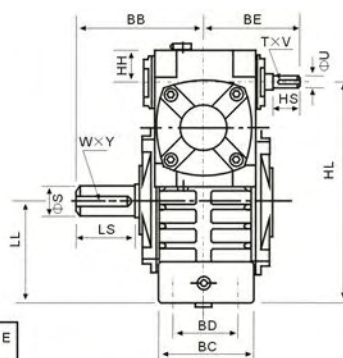

轴指向表示
SHAFT DIRECTION

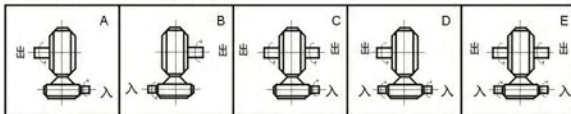

型号 size	减速比 ratio	A	AA	AB	BB	BE	AC	BC	AD	BD	HH	HL	LL	H	ZxL	入力孔Input hole			出力轴output shaft			重量 (kg)
																HS	U	T×V	LS	S	W×Y	
40-70	1/200	286	195	153	131	87	152	86	125	65	35	200	90	215	M10 X25	25	12	4×2.5	60	28	7×4	19
50-80	1/300	297	197	144	142	108	169	102	140	70	35	235	105	250	M12X28	30	12	4×2.5	65	32	10×4.5	28
60-100	1/400	363	231	175	169	120	216	117	180	90	42	290	130	310	M12X30	40	15	5×3	75	38	10×4.5	43
70-120	1/500	408	256	193	190	140	256	124	220	100	55	345	155	370	M14X32	40	18	5×3	85	45	12×4.5	64
80-135	1/600	471	298	226	210	160	296	147	260	110	65	400	185	425	M16X35	50	22	7×4	95	55	16×6	99
100-155	1/800	555	354	269	252	190	345	185	280	120	80	458	203	461	M16X35	50	25	7×4	110	60	18×7	136
120-175	1/900	598	379	287	255	219	374	192	320	140	95	518	223	521	M16X35	65	30	7×4	110	65	18×7	193
135-200	662	425	318	319	256	412	230	360	150	105	580	245	575	M20X36	75	35	10×5	125	70	20×7.5	280
155-250	795	510	380	385	295	500	285	420	190	103	705	300	700	M24X42	85	40	12×5	155	90	25×9	442

WPEDA

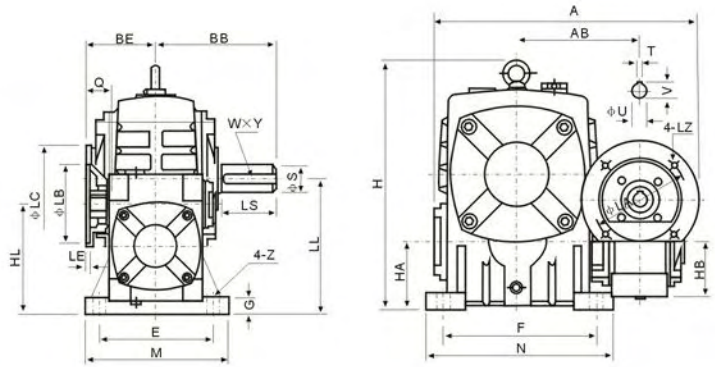

轴指向表示
SHAFT DIRECTION

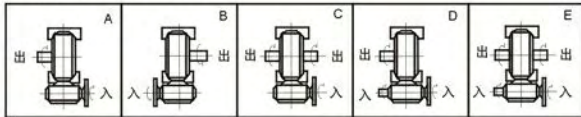

型号 size	入功率 (kw)	减速比 ratio	A	AB	BB	BE	HL	LL	H	HA	HB	M	N	E	F	G	Z	电机法兰flange					入力孔input hole			出力轴output shaft			重量 (kg)
																		LA	LB	LC	LE	LZ	Q	U	T×V	LS	S	W×Y	
40-70	0.12	1/200	314	153	131	75	110	140	236	70	50	150	190	115	150	20	15	115	95	140	4	M8	31	11	4×12.8	60	28	7×4	19
50-80	0.18		314	144	142	83	130	160	268	80	65	170	220	135	180	20	15	115	95	140	4	M8	31	11	4×12.8	65	32	10×4.5	27
60-100	0.37	1/300	387	175	169	91	160	200	336	100	75	190	270	155	220	25	15	130	110	160	4	M8	33	14	5×16.3	75	38	10×4.5	45
70-120	0.37		425	193	190	109	190	240	430	120	90	230	320	180	260	30	18	130	110	160	4	M8	40	14	5×16.3	85	45	12×4.5	75
80-135	0.75	1/500	499	226	210	125	215	270	480	135	105	250	350	200	290	30	18	165	130	200	4.5	M10	48	19	6×21.8	95	55	16×6	103
	1.5																												
100-155	1.5	1/800	570	269	252	148	235	290	531	135	130	275	390	220	320	35	21	165	130	200	4.5	M10	52	24	8×27.3	110	60	18×7	147
120-175	2.2	1/900	631	287	255	181	280	335	600	160	155	310	430	250	350	40	21	215	180	250	5	M12	63	28	8×31.3	110	65	18×7	204
	3.0																												
135-200	3.0	1/900	680	318	319	202	310	375	666	175	185	360	480	290	390	40	24	215	180	250	5	M12	63	28	8×31.3	125	70	20×7.5	298
	4.0																												
155-250	5.5		815	380	385	247	355	450	800	200	203	460	560	380	480	45	28	265	230	300	5	M12	83	38	10×41.3	155	90	25×9	470

WPEDS

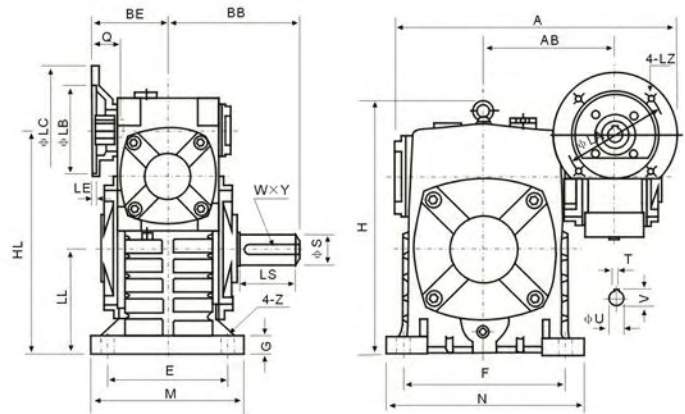

轴指向表示
SHAFT DIRECTION

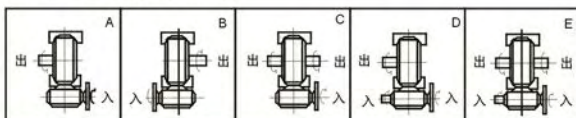

型号 size	入功率 (kw)	减速比 ratio	A	AB	BB	BE	HL	LL	H	M	N	E	F	G	Z	电机法兰flange					入力孔input hole			出力轴output shaft			重量 (kg)
																LA	LB	LC	LE	LZ	Q	U	T×V	LS	S	W×Y	
40-70	0.12	1/200	314	153	131	75	215	105	238	150	190	115	150	20	15	115	95	140	4	M8	31	11	4×12.8	60	28	7×4	19
50-80	0.18		314	144	142	83	250	120	273	170	220	135	180	20	15	115	95	140	4	M8	31	11	4×12.8	65	32	10×4.5	27
60-100	0.37	1/300	387	175	169	91	310	150	334	190	270	155	220	25	15	130	110	160	4	M8	33	14	5×16.3	75	38	10×4.5	45
70-120	0.37		425	193	190	109	370	180	423	230	320	180	260	30	18	130	110	160	4	M8	40	14	5×16.3	85	45	12×5	75
80-135	0.75	1/500	499	226	210	125	430	215	482	250	350	200	290	30	18	165	130	200	4.5	M10	48	19	6×21.8	95	55	16×6	103
	1.5																										
100-155	1.5	1/800	570	269	252	148	490	235	541	275	390	220	320	35	21	165	130	200	4.5	M10	52	24	8×27.3	110	60	18×7	147
120-175	2.2	1/900	631	287	255	181	555	260	600	310	430	250	350	40	21	215	180	250	5	M12	63	28	8×31.3	110	65	18×7	204
	3.0																										
135-200	3.0	1/900	680	318	319	202	625	290	677	360	480	290	390	40	24	215	180	250	5	M12	63	28	8×31.3	125	70	20×7.5	298
	4.0																										
155-250	5.5		815	380	385	247	755	350	824	460	560	380	480	45	28	265	230	300	5	M12	83	38	10×41.3	155	90	25×9	470

WPEDX



WPEDO

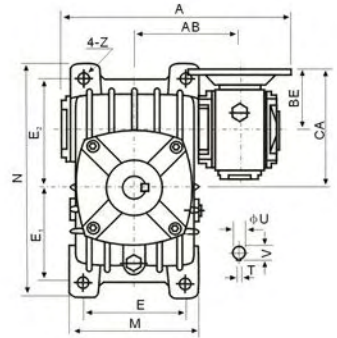
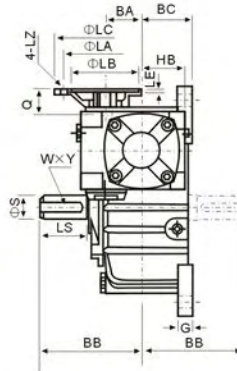

WPEDX轴指向表示
SHAFT DIRECTION

WPEDO轴指向表示
SHAFT DIRECTION

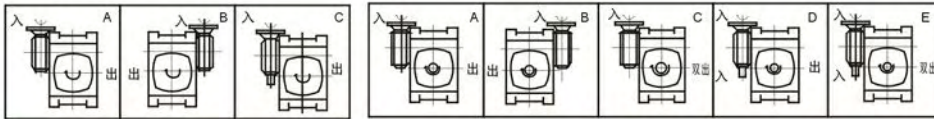

型号 size	入功率 (kw)	减速比 ratio	A	AB	BA	BB	BC	BE	HB	CA	M	N	E	E ₁	E ₂	G	Z	电机法兰flange				入力孔input hole			出力轴output shaft			重量 (kg)	
																		LA	LB	LC	LE	LZ	Q	U	T×V	LS	S	W×Y	
40-70	0.12		314	153	40	131	65	75	50	145	156	295	120	120	135	20	15	115	95	140	4	M8	31	11	4×12.8	60	28	7×4	19
50-80	0.18		314	144	50	142	70	83	65	163	175	320	140	130	150	20	15	115	95	140	4	M8	31	11	4×12.8	65	32	10×4.5	27
60-100	0.37		387	175	60	169	90	91	75	191	224	375	190	155	180	26	15	130	110	160	4	M8	33	14	5×16.3	75	38	10×4.5	45
70-120	0.37	1/200	425	193	70	190	100	109	90	229	266	450	220	185	215	30	18	130	110	160	4	M8	40	14	5×16.3	85	45	12×4.5	65
	0.75	1/300	445				111		231								165	130	200	4	M10	42	19	6×21.8					
80-135	0.75	1/400	499	226	80	210	110	125	105	260	306	495	260	210	235	30	18	165	130	200	4.5	M10	48	19	6×21.8	95	55	16×6	98
	1.5	1/500																				52	24	8×27.3					
100-155	1.5	1/600	570	269	100	252	140	148	130	303	350	590	290	245	295	35	21	165	130	200	4.5	M10	52	24	8×27.3	110	60	18×7	152
120-175	2.2	1/800	631	287	120	255	150	181	155	356	394	640	320	267	323	40	21	215	180	250	5	M12	63	28	8×31.3	110	65	18×7	194
	3.0	1/900																											
135-200	3.0	680	318	135	319	175	202	185	402	440	710	370	290	360	40	24	215	180	250	5	M12	63	28	8×31.3	125	70	20×7.5	283
	4.0																												
155-250	5.5		815	380	155	385	200	247	203	497	510	860	440	350	440	45	28	265	230	300	5	M12	83	38	10×41.3	155	90	25×9	450

WPWED



轴指向表示
SHAFT DIRECTION

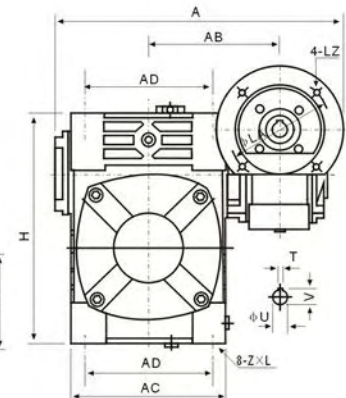
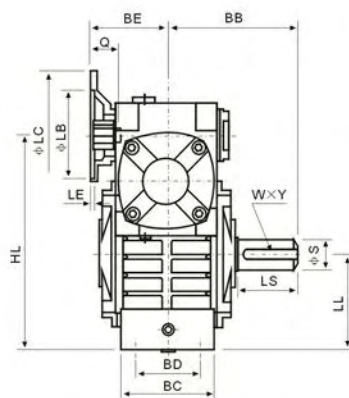
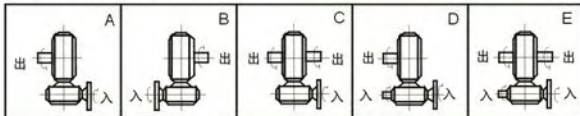

型号 size	入功率 (kw)	减速比 ratio	A	AB	BB	BE	AC	BC	AD	BD	HL	LL	H	ZxL	电机法兰flange				入力孔input hole			出力轴output shaft			重量 (kg)	
															LA	LB	LC	LE	LZ	Q	U	T×V	LS	S	W×Y	
40-70	0.12		314	153	131	75	152	86	125	65	200	90	215	M10 X25	115	95	140	4	M8	31	11	4×12.8	60	28	7×4	19
50-80	0.18		314	144	142	83	169	102	140	70	235	105	250	M12X28	115	95	140	4	M8	31	11	4×12.8	65	32	10×4.5	28
60-100	0.37	1/200	387	175	169	91	216	117	180	90	290	130	310	M12X30	130	110	160	4	M8	33	14	5×16.3	75	38	10×4.5	44
70-120	0.37	1/300	425	193	190	109	256	124	220	100	345	155	370	M14X32	130	110	160	4	M8	40	14	5×16.3	85	45	12×4.5	66
	0.75	1/400	445			111									165	130	200	4	M10	42	19	6×21.8				
80-135	0.75	1/500	499	226	210	125	296	147	260	110	400	185	425	M16X35	165	130	200	4.5	M10	48	19	6×21.8	95	55	16×6	101
	1.5	1/600																		52	24	8×27.3				
100-155	1.5	1/800	570	269	252	148	345	185	280	120	458	203	461	M16X35	165	130	200	4.5	M10	52	24	8×27.3	110	60	18×7	139
120-175	2.2	1/900	631	287	255	181	374	192	320	140	518	223	521	M16X35	215	180	250	5	M12	63	28	8×31.3	110	65	18×7	196
135-200	3.0	680	318	319	202	412	230	360	150	580	245	575	M20X36	215	180	250	5	M12	63	28	8×31.3	125	70	20×7.5	285
	4.0																									
155-250	5.5		815	380	385	247	500	285	420	190	705	300	700	M24X42	265	230	300	5	M12	83	38	10×41.3	155	90	25×9	450

WPEKA

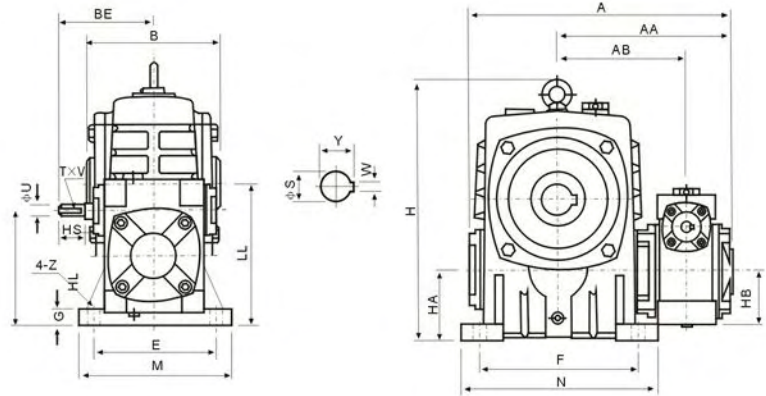

轴指向表示
SHAFT DIRECTION

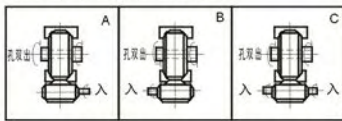

型号 size	减速比 ratio	A	AA	AB	B	BE	HL	LL	H	HA	HB	M	N	E	F	G	Z	输入轴input shaft			出力轴output shaft		重量 (kg)
																		HS	U	T×V	S	W×Y	
40-70	1/200	286	195	153	130	87	110	140	236	70	50	150	190	115	150	20	15	25	12	4×2.5	30	8×33.3	20
50-80	1/300	297	197	144	150	108	130	160	268	80	65	170	220	135	180	20	15	30	12	4×2.5	35	10×38.3	27
60-100	1/400	363	231	175	160	120	160	200	336	100	75	190	270	155	220	25	15	40	15	5×3	40	12×43.3	44
70-120	1/500	408	256	193	175	140	190	240	430	120	90	230	320	180	260	30	18	40	18	5×3	45	14×48.8	73
80-135	1/600	471	298	226	210	160	215	270	480	135	105	250	350	200	290	30	18	50	22	7×4	60	18×64.4	101
100-155	1/800	555	354	269	256	190	235	290	531	135	130	275	390	220	320	35	21	50	25	7×4	70	20×74.9	144
120-175	1/900	598	379	287	282	219	280	335	600	160	155	310	430	250	350	40	21	65	30	7×4	80	22×85.4	201
135-200	662	425	318	320	256	310	375	666	175	185	360	480	290	390	40	24	75	35	10×4.5	85	22×90.4	293
155-250	795	510	380	400	295	355	450	800	200	203	460	560	380	480	45	28	85	40	12×5	110	28×116.4	462

WPEKS

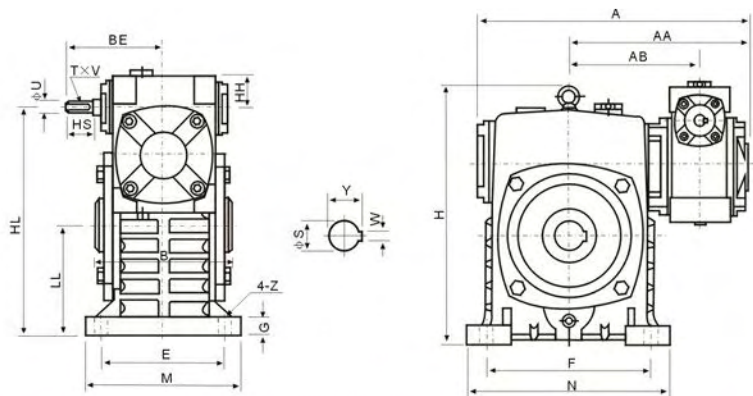

轴指向表示
SHAFT DIRECTION

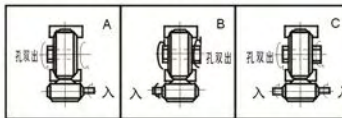

型号 size	减速比 ratio	A	AA	AB	B	BE	HH	HL	LL	H	M	N	E	F	G	Z	输入轴input shaft			出力轴output shaft		重量 (kg)
																	HS	U	T×V	S	W×Y	
40-70	1/200	286	195	153	130	87	35	215	105	238	150	190	115	150	20	15	25	12	4×2.5	30	8×33.3	20
50-80	1/300	297	197	144	150	108	35	250	120	273	170	220	135	180	20	15	30	12	4×2.5	35	10×38.3	27
60-100	1/400	363	231	175	160	120	42	310	150	334	190	270	155	220	25	15	40	15	5×3	40	12×43.3	44
70-120	1/500	408	256	193	175	140	55	370	180	423	230	320	180	260	30	18	40	18	5×3	45	14×48.8	73
80-135	1/600	471	298	226	210	160	65	430	215	482	250	350	200	290	30	18	50	22	7×4	60	18×64.4	101
100-155	1/800	555	354	269	256	190	80	490	235	541	275	390	220	320	35	21	50	25	7×4	70	20×74.9	144
120-175	1/900	598	379	287	282	219	95	555	260	600	310	430	250	350	40	21	65	30	7×4	80	22×85.4	201
135-200	662	425	318	320	256	105	625	290	677	360	480	290	390	40	24	75	35	10×4.5	85	22×90.4	293
155-250	795	510	380	400	295	103	755	350	824	460	560	380	480	45	28	85	40	12×5	110	28×116.4	462

WPWEKO

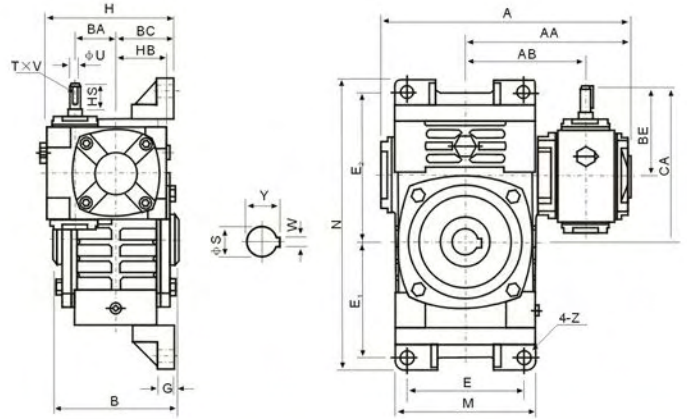

轴指向表示
SHAFT DIRECTION

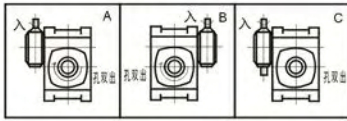

型号 size	减速比 ratio	输入轴input shaft														输出轴output shaft		重量 (kg)						
		A	AA	AB	B	BA	BC	BE	HB	CA	H	M	N	E	E ₁	E ₂	G		Z	HS	U	T×V	S	W×Y
40-70	1/200	286	195	153	130	40	65	87	50	157	140	152	305	120	120	155	20	15	25	12	4×2.5	30	8×33.3	19.5
50-80	1/300	297	197	144	150	50	70	108	65	188	155	174	350	140	140	180	20	15	30	12	4×2.5	35	10×38.3	30.5
60-100	1/400	363	231	175	160	60	90	120	76	222	192	224	410	190	165	215	22	15	40	15	5×3	40	12×43.3	47
70-120	1/500	408	256	193	175	70	100	140	90	260	225	264	494	220	195	255	25	18	40	18	5×3	45	14×48.8	69
80-135	1/600	471	298	226	210	80	110	160	105	295	255	304	559	260	230	285	30	18	50	22	7×4	60	18×64.4	105
100-155	1/800	555	354	269	256	100	140	190	130	345	320	345	605	290	250	305	35	21	50	25	7×4	70	20×74.9	163
120-175	1/800	598	379	287	282	120	150	219	155	394	365	374	675	320	273	348	40	21	65	30	7×4	80	22×85.4	208
135-200	1/900	662	425	318	320	135	175	256	185	456	415	424	749	370	305	390	40	24	75	35	10×4.5	85	22×90.4	302
155-250	795	510	380	400	155	200	295	203	545	458	510	920	440	375	475	45	28	85	40	12×5	110	28×116.4	476

WPWEK

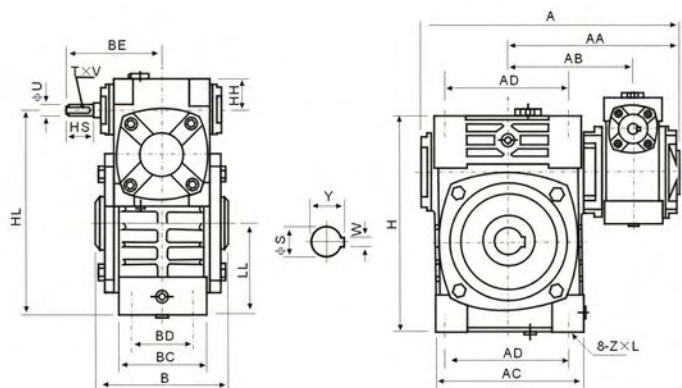

轴指向表示
SHAFT DIRECTION

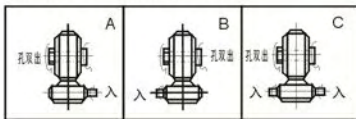

型号 size	减速比 ratio	输入轴input shaft														出力轴output shaft		重量 (kg)			
		A	AA	AB	B	BE	AC	BC	AD	BD	HH	HL	LL	H	Z×L	HS	U		T×V	S	W×Y
40-70	1/200 1/300 1/400 1/500 1/600 1/800 1/900	286	195	153	130	87	152	86	125	65	35	200	90	215	M10 X25	25	12	4×2.5	30	8×33.3	17
50-80		297	197	144	150	108	169	102	140	70	35	235	105	250	M12X28	30	12	4×2.5	35	10×38.3	28
60-100		363	231	175	160	120	216	117	180	90	42	290	130	310	M12X30	40	15	5×3	40	12×43.3	43
70-120		408	256	193	175	140	256	124	220	100	55	345	155	370	M14X32	40	18	5×3	45	14×48.8	64
80-135		471	298	226	210	160	296	147	260	110	65	400	185	425	M16X35	50	22	7×4	60	18×64.4	99
100-155		555	354	269	256	190	345	185	280	120	80	458	203	461	M16X35	50	25	7×4	70	20×74.9	136
120-175		598	379	287	282	219	374	192	320	140	95	518	223	521	M16X35	65	30	7×4	80	22×85.4	193
135-200		662	425	318	320	256	412	230	360	150	105	580	245	575	M20X36	75	35	10×4.5	85	22×90.4	280
155-250	795	510	380	400	295	500	285	420	190	103	705	300	700	M24X42	85	40	12×5	110	28×116.4	442	

WPEDKA

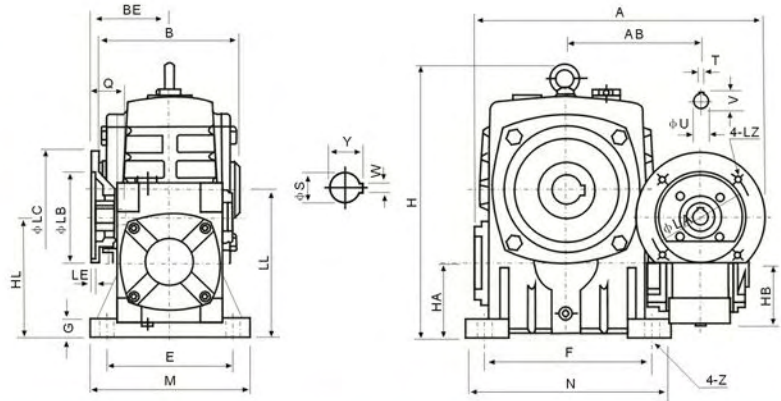

轴指向表示
SHAFT DIRECTION

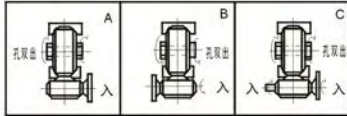

型号 size	入功率 (kw)	减速比 ratio	A	AB	B	BE	HL	LL	H	HA	HB	M	N	E	F	G	Z	电机法兰 flange					入力孔 input hole			出力轴 output shaft		重量 (kg)
																		LA	LB	LC	LE	LZ	Q	U	T×V	S	W×Y	
40-70	0.12	1/200	314	153	130	75	110	140	236	70	50	150	190	115	150	20	15	115	95	140	4	M8	31	11	4×12.8	30	8×33.3	19
50-80	0.18		314	144	150	83	130	160	268	80	65	170	220	135	180	20	15	115	95	140	4	M8	31	11	4×12.8	35	10×38.3	27
60-100	0.37	1/300	387	175	160	91	160	200	336	100	75	190	270	155	220	25	15	130	110	160	4	M8	33	14	5×16.3	40	12×43.3	45
70-120	0.37		425	193	175	109	190	240	430	120	90	230	320	180	260	30	18	130	110	160	4	M8	40	14	5×16.3	45	14×48.8	75
	0.75	1/400	445			111												165	130	200		M10	42	19	6×21.8			
80-135	0.75		499	226	210	125	215	270	480	135	105	250	350	200	290	30	18	165	130	200	4.5	M10	48	19	6×21.8	60	18×64.4	103
100-155	1.5	1/600	570	269	256	148	235	290	531	135	130	275	390	220	320	35	21	165	130	200	4.5	M10	52	24	8×27.3	70	20×74.9	147
120-175	2.2		631	287	282	181	280	335	600	160	155	310	430	250	350	40	21	215	180	250	5	M12	63	28	8×31.3	80	22×85.4	204
135-200	3.0	1/900	680	318	320	202	310	375	666	175	185	360	480	290	390	40	24	215	180	250	5	M12	63	28	8×31.3	85	22×90.4	298
	4.0																											
155-250	5.5		815	380	400	247	355	450	800	200	203	460	560	380	480	45	28	265	230	300	5	M12	83	38	10×41.3	110	28×116.4	470

WPEDKS

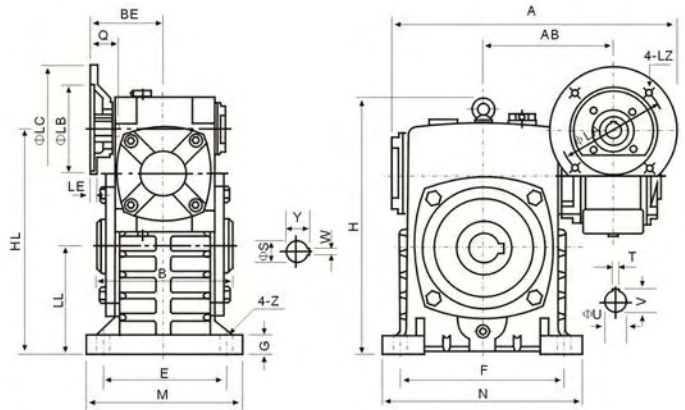

轴指向表示
SHAFT DIRECTION

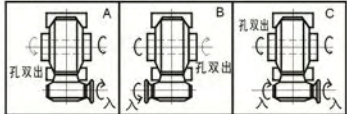

型号 size	入功率 (kw)	减速比 ratio	A	AB	B	BE	HL	LL	H	M	N	E	F	G	Z	电机法兰 flange					入力孔 input hole			出力轴 output shaft		重量 (kg)		
																LA	LB	LC	LE	LZ	Q	U	T×V	S	W×Y			
40-70	0.12	1/200	314	153	130	75	215	105	238	150	190	115	150	20	15	115	95	140	4	M8	31	11	4×12.8	30	8×33.3	19		
50-80	0.18		314	144	150	83	250	120	273	170	220	135	180	20	15	115	95	140	4	M8	31	11	4×12.8	35	10×38.3	27		
60-100	0.37	1/300	387	175	160	91	310	150	334	190	270	155	220	25	15	130	110	160	4	M8	33	14	5×16.3	40	12×43.3	45		
70-120	0.37		425	193	175	109	370	180	423	230	320	180	260	30	18	130	110	160	4	M8	40	14	5×16.3	45	14×48.8	75		
	0.75	1/400	445			111												165	130	200		M10	42	19	6×21.8			
80-135	0.75		499	226	210	125	430	215	482	250	350	200	290	30	18	165	130	200	4.5	M10	48	19	6×21.8	60	18×64.4	103		
100-155	1.5	1/600	570	269	256	148	490	235	541	275	390	220	320	35	21	165	130	200	4.5	M10	52	24	8×27.3	70	20×74.9	147		
120-175	2.2		631	287	282	181	555	260	600	310	430	250	350	40	21	215	180	250	5	M12	63	28	8×31.3	80	22×85.4	204		
135-200	3.0	1/900	680	318	320	202	625	290	677	360	480	290	390	40	24	215	180	250	5	M12	63	28	8×31.3	85	22×90.4	298		
	4.0																											
155-250	5.5		815	380	400	247	755	350	824	460	560	380	480	45	28	265	230	300	5	M12	83	38	10×41.3	110	28×116.4	470		

WPWEDKO

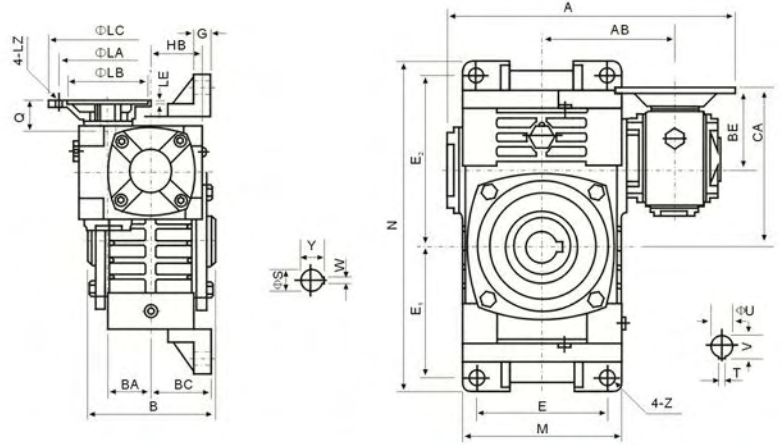

轴指向表示
SHAFT DIRECTION

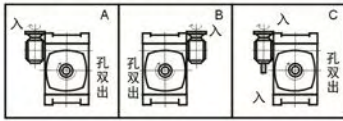

型号 size	入功率 (kw)	减速比 ratio	A	AB	B	BA	BC	BE	HB	CA	M	N	E	E ₁	E ₂	G	Z	电机法兰flange					入力孔input hole			出力轴output shaft		重量 (kg)
																		LA	LB	LC	LE	LZ	Q	U	T×V	S	W×Y	
40-70	0.12	1/200	314	153	130	40	65	75	50	145	152	305	120	120	155	20	15	115	95	140	4	M8	31	11	4×12.8	30	8×33.3	20
50-80	0.18		314	144	150	50	70	83	65	163	174	350	140	140	180	20	15	115	95	140	4	M8	31	11	4×12.8	35	10×38.3	31
60-100	0.37	1/300	387	175	160	60	90	91	75	191	224	410	190	165	215	22	15	130	110	160	4	M8	33	14	5×16.3	40	12×43.3	48
70-120	0.75		425	193	175	70	100	109	90	229	231	264	494	220	195	255	25	18	130	110	160	4	M8	40	14	5×16.3	45	14×48.8
80-135	1.5	1/400	445	226	210	80	110	125	105	260	304	559	260	230	285	30	18	165	130	200	4.5	M10	48	19	6×21.8	60	18×64.4	107
	52																						24	8×27.3				
100-155	1.5	1/600	570	269	256	100	140	148	130	303	345	605	290	250	305	35	21	165	130	200	4.5	M10	52	24	8×27.3	70	20×74.9	166
120-175	2.2																						631	287	282			
135-200	3.0	1/900	680	318	320	135	175	202	185	402	424	749	370	305	390	40	24	215	180	250	5	M12	63	28	8×31.3	85	22×90.4	307
	4.0																						83	38	10×41.3			
155-250	5.5	815	380	400	155	200	247	203	497	510	920	440	375	475	45	28	265	230	300	5	M12	83	38	10×41.3	110	28×116.4	484	

WPWEDK

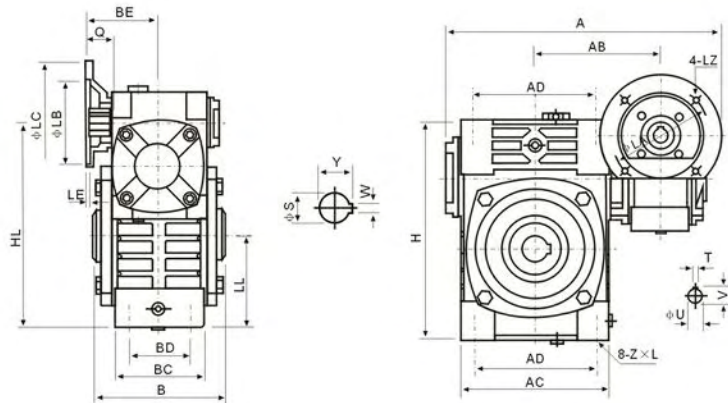

轴指向表示
SHAFT DIRECTION

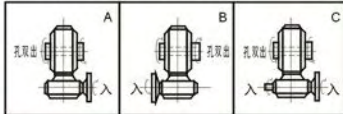

型号 size	入功率 (kw)	减速比 ratio	A	AB	B	BE	AC	BC	AD	BD	HL	LL	H	Z×L	电机法兰flange					入力孔input hole			出力轴output shaft		重量 (kg)
															LA	LB	LC	LE	LZ	Q	U	T×V	S	W×Y	
40-70	0.12	1/200	314	153	130	75	152	86	125	65	200	90	215	M10X25	115	95	140	4	M8	31	11	4×12.8	30	8×33.3	18
50-80	0.18		314	144	150	83	169	102	140	70	235	105	250	M12X28	115	95	140	4	M8	31	11	4×12.8	35	10×38.3	28
60-100	0.37	1/300	387	175	160	91	216	117	180	90	290	130	310	M12X30	130	110	160	4	M8	33	14	5×16.3	40	12×43.3	44
70-120	0.75		425	193	175	109	256	124	220	100	345	155	370	M14X32	130	110	160	4	M8	40	14	5×16.3	45	14×48.8	66
80-135	1.5	1/400	445	226	210	125	296	147	260	110	400	185	425	M16X35	165	130	200	4.5	M10	48	19	6×21.8	60	18×64.4	101
	52																			24	8×27.3				
100-155	1.5	1/600	570	269	256	148	345	185	280	120	458	203	461	M16X35	165	130	200	4.5	M10	52	24	8×27.3	70	20×74.9	139
120-175	2.2																			631	287	282			
135-200	3.0	1/900	680	318	320	202	412	230	360	150	580	245	575	M20X36	215	180	250	5	M12	63	28	8×31.3	85	22×90.4	285
	4.0																			83	38	10×41.3			
155-250	5.5	815	380	400	247	500	285	420	190	705	300	700	M24X42	265	230	300	5	M12	83	38	10×41.3	110	28×116.4	450	

WPW

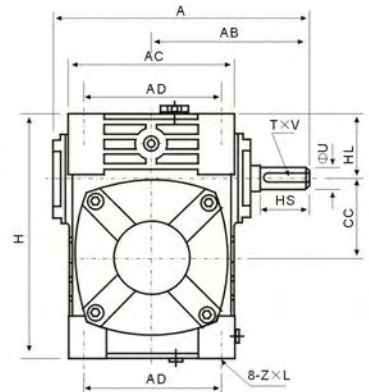
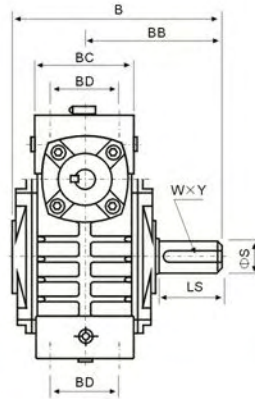

轴指向表示
SHAFT DIRECTION

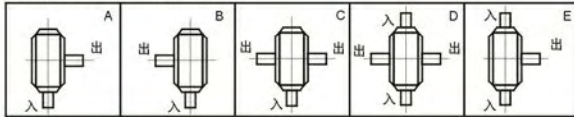

型号 size	减速比 ratio	A	AB	B	BB	AC	BC	AD	BD	CC	HL	H	Z×L	入力轴input shaft			出力轴output shaft			重量 (kg)
														HS	U	T×V	LS	S	W×Y	
40	1/5	143	87	114	74	95	61	78	42	40	35	125	M6×12	25	12	4×2.5	28	14	5×3	4
50		175	108	150	97	111	68	85	50	50	35	150	M6×18	30	12	4×2.5	40	17	5×3	6.5
60	1/10	198	120	168	112	127	76	105	55	60	42	177	M8×20	40	15	5×3	50	22	7×4	9
70		231	140	194	131	152	86	125	65	70	55	215	M10×25	40	18	5×3	60	28	7×4	13
80	1/20	261	160	214	142	169	102	140	70	80	65	250	M12×28	50	22	7×4	65	32	10×4.5	21
100		322	190	254	169	216	117	180	90	100	80	310	M12×30	50	25	7×4	75	38	10×4.5	34
120	1/30	371	219	282	190	256	124	220	100	120	95	370	M14×32	65	30	7×4	85	45	12×4.5	51
135		422	249	317	210	296	147	260	110	135	105	425	M16×35	75	35	10×4.5	95	55	16×6	78
155	1/40	497	295	382	252	345	185	280	120	155	103	461	M16×35	85	40	12×5	110	60	18×7	102
175		534	314	372	255	374	192	320	140	175	123	521	M16×35	85	45	14×5.5	110	65	18×7	142
200	1/60	580	342	456	319	412	230	360	150	200	130	575	M20×36	95	50	14×5.5	125	70	20×7.5	202
250		705	420	552	385	500	285	420	190	250	150	700	M24×42	110	60	18×7	155	90	25×9	340

WPWA

WPWS

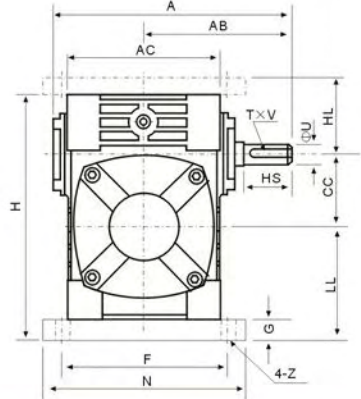
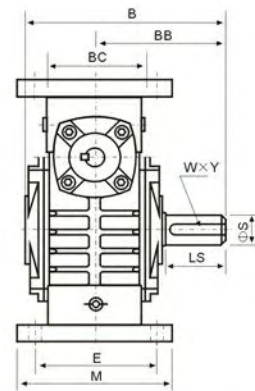

轴指向表示
SHAFT DIRECTION

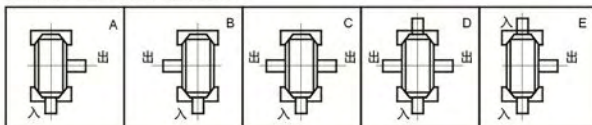

型号 size	减速比 ratio	A	AB	B	BB	AC	BC	CC	HL	LL	H	M	N	E	F	G	Z	入力轴input shaft			出力轴output shaft			重量 (kg)
																		HS	U	T×V	LS	S	W×Y	
40	1/5	143	87	114	74	95	61	40	45	60	135	100	130	80	110	10	10	25	12	4×2.5	28	14	5×3	4.5
50		175	108	150	97	111	68	50	50	80	165	120	140	95	110	15	12	30	12	4×2.5	40	17	5×3	7.5
60	1/10	198	120	168	112	127	76	60	60	93	195	130	150	105	120	18	12	40	15	5×3	50	22	7×4	11.5
70		231	140	194	131	152	86	70	73	108	233	150	190	115	150	18	15	40	18	5×3	60	28	7×4	15.5
80	1/20	261	160	214	142	169	102	80	83	123	268	170	220	135	180	18	15	50	22	7×4	65	32	10×4.5	24
100		322	190	254	169	216	117	100	100	150	330	190	270	155	220	20	15	50	25	7×4	75	38	10×4.5	39
120	1/30	371	219	282	190	256	124	120	120	180	395	230	320	180	260	25	18	65	30	7×4	85	45	12×4.5	57
135		422	249	317	210	296	147	135	135	215	455	250	350	200	290	30	18	75	35	10×4.5	95	55	16×6	85
155	1/40	497	295	382	252	345	185	155	135	235	493	280	380	220	320	32	21	85	40	12×5	110	60	18×7	110
175		534	314	373	255	374	192	175	160	260	558	310	410	250	350	37	21	85	45	14×5.5	110	65	18×7	152
200	1/60	580	342	456	319	412	230	200	175	290	620	355	445	290	390	45	24	95	50	14×5.5	125	70	20×7.5	216
250		705	420	552	385	500	285	250	200	350	750	460	560	380	480	50	28	110	60	18×7	155	90	25×9	350

WPWX



WPWO

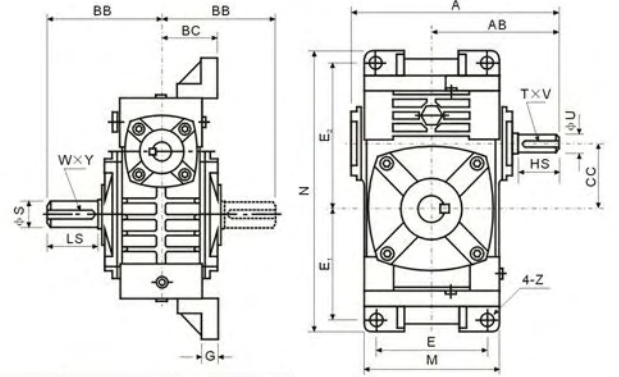

WPWX轴指向表示
SHAFT DIRECTION

WPWO轴指向表示
SHAFT DIRECTION

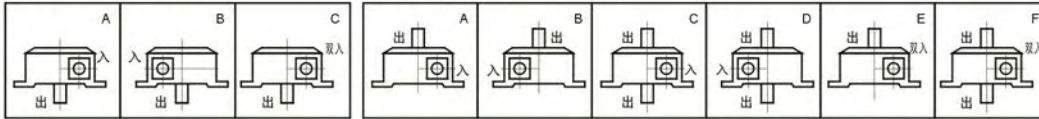

型号 size	减速比 ratio	A	AB	BB	BC	CC	M	N	E	E ₁	E ₂	G	Z	入力轴input shaft			出力轴output shaft			重量 (kg)
														HS	U	T×V	LS	S	W×Y	
40	1/5	143	87	74	45	40	95	187	70	72	97	12	10	25	12	4×2.5	28	14	5×3	5
50		175	108	97	50	50	111	226	90	90	110	14	12	30	12	4×2.5	40	17	5×3	8
60	1/10	198	120	112	55	60	127	257	100	102	129	15	12	40	15	5×3	50	22	7×4	11
70	1/15	231	140	131	65	70	152	305	120	120	155	20	15	40	18	5×3	60	28	7×4	15.5
80	1/20	261	160	142	70	80	174	350	140	140	180	20	15	50	22	7×4	65	32	10×4.5	24
100		322	190	169	90	100	224	410	190	165	215	22	15	50	25	7×4	75	38	10×4.5	38
120	1/25	371	219	190	100	120	264	494	220	195	255	25	18	65	30	7×4	85	45	12×4.5	56
135	1/30	422	249	210	110	135	304	559	260	230	285	30	18	75	35	10×4.5	95	55	16×6	84
155	1/40	497	295	252	140	155	345	605	290	250	305	35	21	85	40	12×5	110	60	18×7	129
175	1/50	534	314	255	150	175	374	675	320	273	348	40	21	85	45	14×5.5	110	65	18×7	157
200	1/60	580	342	319	175	200	424	749	370	305	390	40	24	95	50	14×5.5	125	70	20×7.5	224
250		705	420	385	200	250	510	920	440	375	475	45	28	110	60	18×7	155	90	25×9	374

WPWV



WPWT

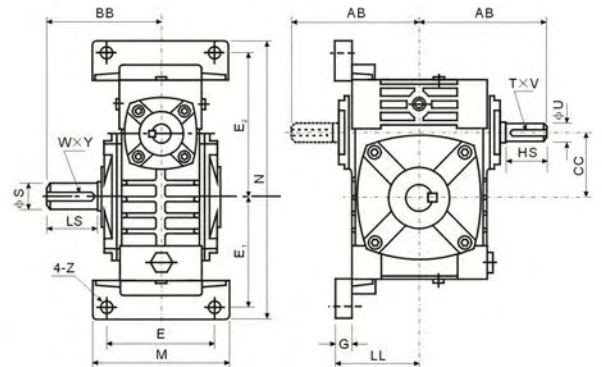

WPWV轴指向表示
SHAFT DIRECTION

WPWT轴指向表示
SHAFT DIRECTION

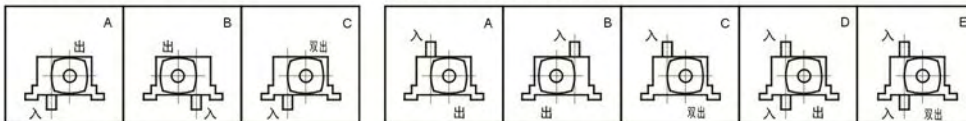

型号 size	减速比 ratio	AB	BB	CC	LL	M	N	E	E ₁	E ₂	G	Z	入力轴input shaft			出力轴output shaft			重量 (kg)
													HS	U	T×V	LS	S	W×V	
40	1/5	87	74	40	63	90	187	70	72	97	12	10	25	12	4×2.5	28	14	5×3	5
50		108	97	50	70	120	226	95	90	110	14	12	30	12	4×2.5	40	17	5×3	8
60	1/10	120	112	60	80	130	257	105	102	129	15	12	40	15	5×3	50	22	7×4	11
70	1/15	140	131	70	95	150	305	115	120	155	20	15	40	18	5×3	60	28	7×4	15.5
80	1/20	160	142	80	105	170	350	135	140	180	20	15	50	22	7×4	65	32	10×4.5	24
100		190	169	100	135	190	410	155	165	215	22	15	50	25	7×4	75	38	10×4.5	38
120	1/25	219	190	120	160	230	494	180	195	255	25	18	65	30	7×4	85	45	12×4.5	56
135	1/30	249	210	135	185	250	559	200	230	285	30	18	75	35	10×4.5	95	55	16×6	84
155	1/40	295	252	155	220	275	605	220	250	305	35	21	85	40	12×5	110	60	18×7	129
175	1/50	314	255	175	240	310	675	250	273	348	40	21	85	45	14×5.5	110	65	18×7	157
200	1/60	342	319	200	280	360	749	290	305	390	40	24	95	50	14×5.5	125	70	20×7.5	224
250		420	385	250	315	460	920	380	375	475	45	28	110	60	18×7	155	90	25×9	374

WPWD



轴指向表示
SHAFT DIRECTION

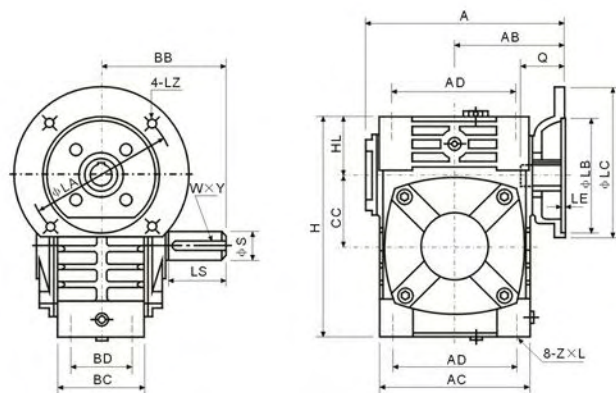
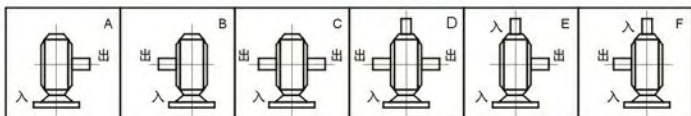

型号 size	入功率 (kw)	减速比 ratio	WPWD											电机法兰flange					入力孔input hole			出力轴output shaft			重量 (kg)
			A	AB	BB	AC	BC	AD	BD	CC	HL	H	Z×L	LA	LB	LC	LE	LZ	Q	U	T×V	LS	S	W×Y	
40	0.12	1/5	135	75	74	95	61	78	42	40	35	125	M6×12	115	95	140	4	M8	31	11	4×12.8	28	14	5×3	4
50	0.18		151	83	97	111	68	85	50	50	35	150	M6×18	115	95	140	4	M8	31	11	4×12.8	40	17	5×3	7
60	0.37		167	91	112	127	76	105	55	60	42	177	M8×20	130	110	160	4	M8	33	14	5×16.3	50	22	7×4	10
70	0.37	1/10	200	109	131	152	86	125	65	70	55	215	M10×25	130	110	160	4	M8	40	14	5×16.3	60	28	7×4	14.5
70	0.75		202	111																					
80	0.75	1/15	225	125	142	169	102	140	70	80	65	250	M12×28	165	130	200	4.5	M10	48	19	6×21.8	65	32	10×4.5	23
100	1.5	1/20	280	148	169	216	117	180	90	100	80	310	M12×30	165	130	200	4.5	M10	52	24	8×27.3	75	38	10×4.5	36.5
120	2.2	1/25	333	181	190	256	124	220	100	120	95	370	M14×32	215	180	250	5	M12	63	28	8×31.3	85	45	12×4.5	54
120	3.0		333	181	190	256	124	220	100	120	95	370	M14×32	215	180	250	5	M12	63	28	8×31.3	85	45	12×4.5	54
135	3.0	1/40	375	202	210	296	147	260	110	135	105	425	M16×35	215	180	250	5	M12	63	28	8×31.3	95	55	16×6	83
155	5.5	1/50	448	247	252	345	185	280	120	155	103	461	M16×35	265	230	300	5	M12	83	38	10×41.3	110	60	18×7	110
175	5.5	1/60	481	262	255	374	192	320	140	175	123	521	M16×35	265	230	300	5	M12	83	38	10×41.3	110	65	18×7	156
200	11.0		543	285	319	412	230	360	150	200	130	575	M20×36	300	250	350	6	M16	114	42	12×45.3	125	70	20×7.5	222
250	11.0	1/60	615	330	385	500	285	420	190	250	150	700	M24×42	300	250	350	6	M16	114	42	12×45.3	155	90	25×9	376

WPWDS



WPWDA



轴指向表示
SHAFT DIRECTION

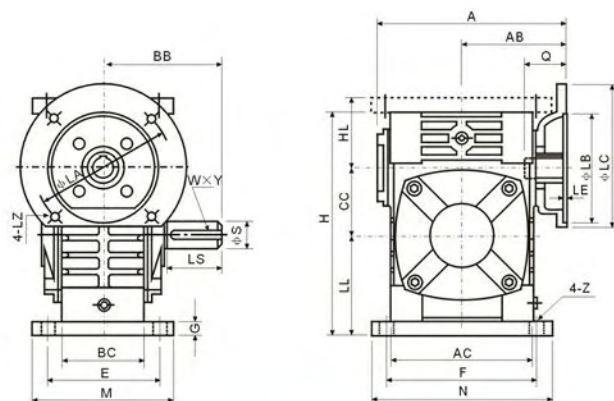
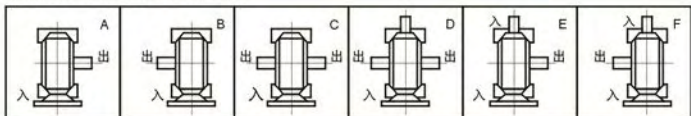

型号 size	入功率 (kw)	减速比 ratio	WPWDS/WPWDA													电机法兰flange					入力孔input hole			出力轴output shaft			重量 (kg)		
			A	AB	BB	AC	BC	CC	HL	LL	H	M	N	E	F	G	Z	LA	LB	LC	LE	LZ	Q	U	T×V	LS		S	W×Y
40	0.12	1/5	135	75	74	95	61	40	45	60	135	100	130	80	110	10	10	115	95	140	4	M8	31	11	4×12.8	28	14	5×3	5
50	0.18		151	83	97	111	68	50	50	80	165	120	140	95	110	15	12	115	95	140	4	M8	31	11	4×12.8	40	17	5×3	8
60	0.37		167	91	112	127	76	60	60	93	195	130	150	105	120	18	12	130	110	160	4	M8	33	14	5×16.3	50	22	7×4	12.5
70	0.37	1/10	200	109	131	152	86	70	73	108	233	150	190	115	150	18	15	130	110	160	4	M8	40	14	5×16.3	60	28	7×4	17
70	0.75		202	111																									
80	0.75	1/15	225	125	142	169	102	80	83	123	268	170	220	135	180	18	15	165	130	200	4.5	M10	48	19	6×21.8	65	32	10×4.5	26
100	1.5	1/20	280	148	169	216	117	100	100	150	330	190	270	155	220	20	15	165	130	200	4.5	M10	52	24	8×27.3	75	38	10×4.5	41.5
120	2.2	1/25	333	181	190	256	124	120	120	180	395	230	320	180	260	25	18	215	180	250	5	M12	63	28	8×31.3	85	45	12×4.5	60
120	3.0		333	181	190	256	124	120	120	180	395	230	320	180	260	25	18	215	180	250	5	M12	63	28	8×31.3	85	45	12×4.5	60
135	3.0	1/40	375	202	210	296	147	135	135	215	455	250	350	200	290	30	18	215	180	250	5	M12	63	28	8×31.3	95	55	16×6	90
155	5.5	1/50	448	247	252	345	185	155	135	235	493	280	380	220	320	32	21	265	230	300	5	M12	83	38	10×41.3	110	60	18×7	118
175	5.5	1/60	481	262	255	374	192	175	160	260	558	310	410	250	350	37	21	265	230	300	5	M12	83	38	10×41.3	110	65	18×7	167
200	11.0		543	285	319	412	230	200	175	290	620	355	445	290	390	45	24	300	250	350	6	M16	114	42	12×45.3	125	70	20×7.5	237
250	11.0	1/60	615	330	385	500	285	250	200	350	750	460	560	380	480	50	28	300	250	350	6	M16	114	42	12×45.3	155	90	25×9	395

WPWKO



轴指向表示
SHAFT DIRECTION

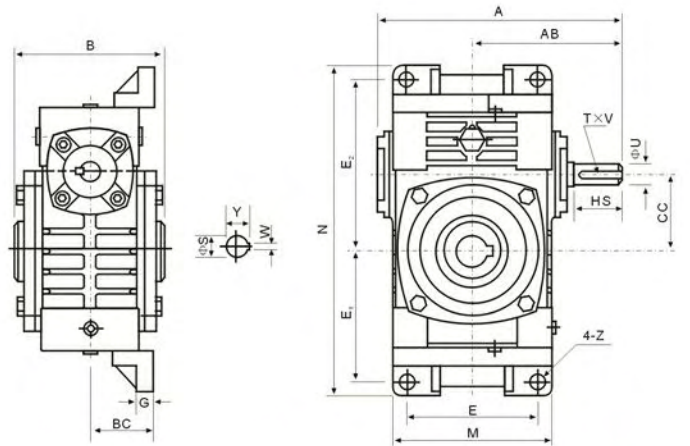
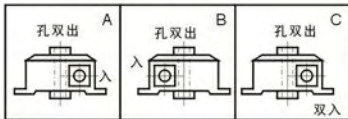

型号 size	减速比 ratio	A	AB	B	BC	CC	M	N	E	E ₁	E ₂	G	Z	入力轴input shaft			出力轴output shaft		重量 (kg)
														HS	U	T×V	S	W×Y	
40	1/5	143	87	85	45	40	95	187	70	72	97	12	10	25	12	4×2.5	16	6×18.8	5
50		175	108	105	50	50	111	226	90	90	110	14	12	30	12	4×2.5	20	6×22.8	8
60	1/10	198	120	110	55	60	127	257	100	102	129	15	12	40	15	5×3	25	8×28.3	11
70	1/15	231	140	130	65	70	152	305	120	120	155	20	15	40	18	5×3	30	8×33.3	15.5
80		261	160	150	70	80	174	350	140	140	180	20	15	50	22	7×4	35	10×38.3	24
100	1/20	322	190	160	90	100	224	410	190	165	215	22	15	50	25	7×4	40	12×43.3	38
120	1/25	371	219	175	100	120	264	494	220	195	255	25	18	65	30	7×4	45	14×48.8	56
135	1/30	422	249	210	110	135	304	559	260	230	285	30	18	75	35	10×4.5	60	18×64.4	84
155	1/40	497	295	256	140	155	345	605	290	250	305	35	21	85	40	12×5	70	20×74.9	129
175	1/50	534	314	282	150	175	374	675	320	273	348	40	21	85	45	14×5.5	80	22×85.4	157
200	1/60	580	342	320	175	200	424	749	370	305	390	40	24	95	50	14×5.5	85	22×90.4	224
250		705	420	400	200	250	510	920	440	375	475	45	28	110	60	18×7	110	28×116.4	374

WPWKT

WPWKV



轴指向表示
SHAFT DIRECTION

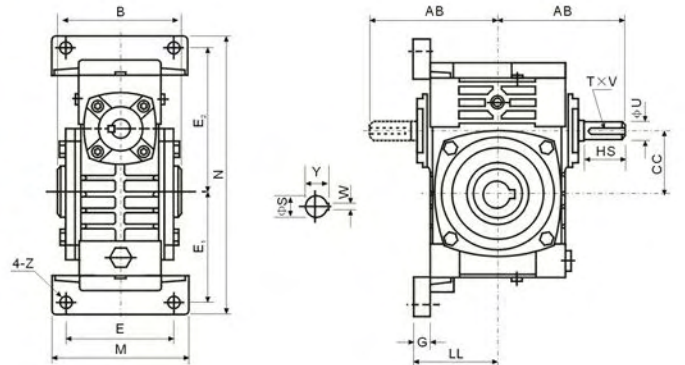
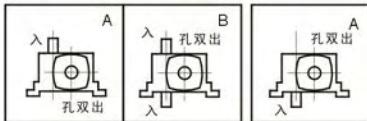

型号 size	减速比 ratio	AB	B	CC	LL	M	N	E	E ₁	E ₂	G	Z	入力轴input shaft			出力轴output shaft		重量 (kg)
													HS	U	T×V	S	W×Y	
40	1/5	87	85	40	63	90	187	70	72	97	12	10	25	12	4×2.5	16	6×18.8	5
50		108	105	50	70	120	226	95	90	110	14	12	30	12	4×2.5	20	6×22.8	8
60	1/10	120	110	60	80	130	257	105	102	129	15	12	40	15	5×3	25	8×28.3	11
70	1/15	140	130	70	95	150	305	115	120	155	20	15	40	18	5×3	30	8×33.3	15.5
80		160	150	80	105	170	350	135	140	180	20	15	50	22	7×4	35	10×38.3	24
100	1/20	190	160	100	135	190	410	155	165	215	22	15	50	25	7×4	40	12×43.3	38
120	1/25	219	175	120	160	230	494	180	195	255	25	18	65	30	7×4	45	14×48.8	56
135	1/30	249	210	135	185	250	559	200	230	285	30	18	75	35	10×4.5	60	18×64.4	84
155	1/40	295	256	155	220	275	605	220	250	305	35	21	85	40	12×5	70	20×74.9	129
175	1/50	314	282	175	240	310	675	250	273	348	40	21	85	45	14×5.5	80	22×85.4	157
200	1/60	342	320	200	280	360	749	290	305	390	40	24	95	50	14×5.5	85	22×90.4	224
250		420	400	250	315	460	920	380	375	475	45	28	110	60	18×7	110	28×116.4	374

※ 入力轴功率及出力轴力矩表
 ※ WP.WPK.WPWK (A.S.X.O.T.V) 型

Input and Output

■ 入力轴转速 speed of input shaft: 1500r/min

功率及力矩 power and moment 减速比ratio 型号size	入力轴功率input(kW)									出力轴力矩output(Nm)								
	1/5	1/10	1/15	1/20	1/25	1/30	1/40	1/50	1/60	1/5	1/10	1/15	1/20	1/25	1/30	1/40	1/50	1/60
40	0.48	0.40	0.33	0.26	0.24	0.22	0.16	0.14	0.12	17	19	23	20	25	25	24	26	26
50	0.80	0.65	0.52	0.40	0.37	0.34	0.27	0.24	0.20	28	31	36	35	38	39	40	43	43
60	1.25	1.00	0.82	0.65	0.59	0.54	0.45	0.40	0.32	45	50	58	56	68	62	71	75	70
70	1.95	1.60	1.35	1.10	0.96	0.82	0.67	0.61	0.52	70	83	98	101	112	99	104	113	113
80	2.65	2.20	1.78	1.36	1.28	1.20	0.90	0.80	0.75	95	113	133	120	149	151	140	145	163
100	4.45	3.60	3.10	2.60	2.35	2.10	1.68	1.30	1.00	170	193	237	258	284	277	291	257	229
120	6.15	5.20	4.35	3.50	3.25	3.00	2.20	1.90	1.50	242	262	336	361	404	413	392	399	355
135	11.25	9.75	7.85	6.00	5.50	5.00	3.69	2.89	2.30	460	540	622	619	696	707	607	626	562
155	14.50	12.80	9.90	7.00	6.53	6.00	4.40	3.61	3.00	655	709	785	722	842	848	784	770	791
175	21.50	17.30	13.60	10.00	9.13	8.30	6.18	4.85	4.07	823	958	1091	1044	1221	1189	1133	1127	1078
200		22.60	18.20	13.86	12.75	11.67	8.78	6.71	5.58		1280	1477	1482	1643	1782	1654	1516	1449
250		33.20	27.40	21.60	20.00	18.43	14.00	10.43	8.62		1881	2266	2310	2579	2745	2674	2357	2371

※ 入力轴功率及出力轴力矩表
 ※ WPD.WPDK.WPWD.WPWDK (A.S.X.O.T.V) 型

Input and Output

■ 入力轴转速 speed of input shaft: 1500r/min
 (配用A02或Y系列电机 Matching electric motor series A02 or Y)

功率及力矩 power and moment 减速比ratio 型号size	入力轴功率input(kW)									出力轴力矩output(Nm)								
	1/5	1/10	1/15	1/20	1/25	1/30	1/40	1/50	1/60	1/5	1/10	1/15	1/20	1/25	1/30	1/40	1/50	1/60
40	0.12									4	6	8	9	13	14	15	19	20
50	0.18									6	9	12	16	19	20	24	31	35
60	0.37									11	19	26	34	42	42	58	67	73
70	0.75				0.37					23	39	54	70	87	95	58	68	70
80	1.5				0.75					43	77	112	142	174	189	137	150	154
100	1.5									58	80	115	149	181	198	260	307	344
120	3				2.2					72	151	232	310	372	413	392	480	521
135	4				3					122	219	321	413	509	565	542	649	690
155	5.5									145	270	411	525	709	760	904	1100	1260
175	7.5				5.5					210	415	602	783	1002	1074	1008	1278	1450
200	11										623	892	1176	1417	1680	2072	2485	2856
250	15				11						850	1246	1604	1933	2234	2101	2486	3025

※ 入力轴功率及出力轴力矩表
 ※ WPE.WPEK.WPWE.WPWEK
 ※ WPED.WPEDK.WPWED.WPWEDK (A.S.X.O) 型

Input and Output

■ 入力轴转速 speed of input shaft: 1500r/min

型号 size	功率及力矩 power and moment	WPE.WPEK.WPWE.WPWEK							WPED.WPEDK.WPWED.WPWEDK						
		减速比 ratio							减速比 ratio						
		1/200	1/300	1/400	1/500	1/600	1/800	1/900	1/200	1/300	1/400	1/500	1/600	1/800	1/900
40-70	入力轴功率 (kW)	0.48	0.34	0.28	0.25	0.23	0.20	0.17	0.12	0.12	0.12	0.12	0.12	0.12	0.12
	出力轴力矩 (Nm)	250	250	250	250	250	250	250	63	88	107	120	130	150	177
50-80	入力轴功率 (kW)	0.65	0.51	0.42	0.38	0.31	0.29	0.25	0.18	0.18	0.18	0.18	0.18	0.18	0.18
	出力轴力矩 (Nm)	350	350	350	350	350	350	350	97	124	150	166	203	217	252
60-100	入力轴功率 (kW)	0.95	0.67	0.52	0.44	0.440	0.35	0.33	0.37	0.37	0.37	0.37	0.37	0.37	0.37
	出力轴力矩 (Nm)	500	500	500	500	500	500	500	195	276	356	420	463	529	561
70-120	入力轴功率 (kW)	1.64	1.18	0.91	0.84	0.71	0.58	0.54	0.75	0.75	0.75	0.75	0.75	0.37	0.75
	出力轴力矩 (Nm)	840	840	840	840	840	840	840	384	534	692	750	887	536	1166
80-135	入力轴功率 (kW)	2.5	1.75	1.39	1.19	1.08	0.98	0.85	1.5	1.5	1.5	1.5	1.5	0.75	1.5
	出力轴力矩 (Nm)	1400	1400	1400	1400	1400	1400	1400	616	880	1108	1294	1426	1071	1811
100-155	入力轴功率 (kW)	3.69	2.92	2.41	2.07	1.89	1.69	1.50	1.5	1.5	1.5	1.5	1.5	1.5	1.5
	出力轴力矩 (Nm)	2100	2100	2100	2100	2100	2100	2100	854	1079	1307	1522	1667	1864	2100
120-175	入力轴功率 (kW)	5.09	3.91	3.27	2.72	2.53	2.05	2.05	3	3	3	3	3	2.2	3
	出力轴力矩 (Nm)	3050	3050	3050	3050	3050	3050	3050	1798	2340	2798	3364	3616	2685	4463
135-200	入力轴功率 (kW)	7.22	5.41	4.46	3.83	3.46	2.91	2.71	4	4	4	4	4	3	4
	出力轴力矩 (Nm)	3950	3950	3950	3950	3950	3950	3950	2188	2920	3543	4125	4566	4072	5830
155-250	入力轴功率 (kW)	11.71	8.14	6.00	5.14	4.67	4.07	3.67	5.5	5.5	5.5	5.5	5.5	5.5	5.5
	出力轴力矩 (Nm)	6050	6050	6050	6050	6050	6050	6050	2841	4087	5546	6473	7125	8175	9066

※ WP系列出力轴悬臂负荷表

型号	输入轴转速 (r/min)	出力轴悬臂负荷(N)								
		减速比								
		1/5	1/10	1/15	1/20	1/25	1/30	1/40	1/50	1/60
40	1500	540	540		540	540	540	540	540	540
	1000	540	540		540	540	540	540	540	540
50	1500	700	840	870	870	870	870	870	870	870
	1000	780	870	870	870	870	870	870	870	870
60	1500	780	780	870	1000	1000	1100	1300	1500	1500
	1000	800	800	950	1100	1100	1200	500	1500	1500
70	1500	870	870	1200	1350	1400	1550	900	2000	2000
	1000	920	920	1300	1500	600	1700	2000	2000	2000
80	1500	1250	1250	1600	1950	2000	2100	2500	2700	2900
	1000	1350	1350	1700	2100	2200	2300	2700	2900	2900
100	1500	1260	1260	1600	1950	2000	2100	2500	2700	3100
	1000	1350	1350	1700	2100	2200	2300	2700	3000	3300
120	1500	1350	1350	1700	2100	2100	2200	2800	3150	3500
	1000	1400	1450	1780	2200	2300	2380	2980	3350	3810
135	1500	2100	2300	2800	3300	3400	3600	4400	5000	5600
	1000	2200	2500	2950	3550	3700	3900	4700	5400	6000
147	1500	2700	3000	3500	4200	4300	4500	5500	6400	7200
	1000	2900	3300	3800	4500	4700	5000	6000	6900	7500
155	1500	5800	6300	7800	9300	10000	10500	10800	10800	10800
	1000	6000	6600	8200	10000	10500	10800	10800	10800	10800
175	1500	6600	7200	8700	9900	10500	11500	12700	13200	13200
	1000	7000	7650	9500	10500	11000	12000	13200	13200	13200
200	1500	7400	8400	9900	10650	11000	12000	13500	16000	16000
	1000	7800	8800	10500	11600	12000	13200	16000	16000	16000
250	1500		8700	10200	12400	13000	14700	18300	19800	19800
	1000		11000	13200	16800	17000	18000	19800	19800	19800

※ 蜗杆减速机的选型
 ※ Choice of Lubricant

■ 选型依据的主要指标

- ◆ 输入轴功率
- ◆ 出力轴力矩
- ◆ 两者的关系式 $P = \frac{T \times n_2}{9550 \times n}$ (公式一)

P-输入轴功率单位KW

T-出力轴力矩单位N.M

n-减速机的传动效率

n_2 -出力轴的转速r/min。

■ 选型计算步骤

- ◆ 出力轴的理论力矩:

是根据使用要求, 计算出的出力轴的理论输出力矩 T_1 ,

- ◆ 出力轴理论力矩的修正:

由于使用环境温度的不同, 与工作运转中受力变化, 所以在进行选型前对计算出的理论力矩需要进行必要的修正。以保证减速机的正常运转和寿命。

$$T = T_1 \times a_1 \times a_2 \text{ (公式二)}$$

T-选型用力矩

T_1 -理论计算力矩

a_1 -环境温度系数(数据查表一)

a_2 -工作运转过程中受力变化状况系数(查表二)

- ◆ 工作环境温度修正系数 a_1

表一

环境温度℃	10~25	26~30	31~40	41~50
a_1	1	1:1	1	1.6

◆ 工作状况修正系数 a_2

表二

运行状况	24小时内运行的实际时间(小时h)		
	≤2	>2~10	>10~24
平稳运行	0.8	1	1.2
中度冲击载荷	1	1.2	1.4
较大冲击载荷	1.25	1.5	1.75
备注	如果运行过程中,每小时开启次数或正反转,换向次数等于或大于12次那么上表中的数值应再乘以1.2。		

◆ 输入轴功率计算

$$P = \frac{T x n_2}{9550 x n}$$

P-输入轴功率。单位KW

T-经过计算修正过的力矩数值。单位N·M

n_2 -出力轴的转速,由用户的使用条件要求计算而得。单位r/min。

n -减速机的传动效率系数,其值由下面表三中查取

表三

速比	1:10	1:15	1:20	1:25	1:30	1:40	1:50	1:60
η	0.76~0.90	0.75~0.86	0.74~0.84	0.72~0.82	0.68~0.70	0.65~0.75	0.62~0.72	0.60~0.70

■ 选型原则

- ◆ 按上面两项计算结果,对照产品说明书中所给定的数值进行选取,被选型号的两项数值,均应接近或大于计算的结果。
- ◆ 在选择减速机的时候注意输入轴的转速不宜太高,一般在600~1600r/min之间为宜。

[例一]

某客户有如下图的结构要求,求购一台WPS型, 1: 30的减速机,要求将800kg的重物以8M/min的速度提升。

已知: 输入轴转速1450r/min, 减速机出力轴与卷绳轮之间的第一节传动由三角皮带进行, 减速比为1:4。减速机在20℃下使用, 每天工作8H, 有中等载荷的冲击, 每小时开启转换6次, 问选用多大型号的合适?

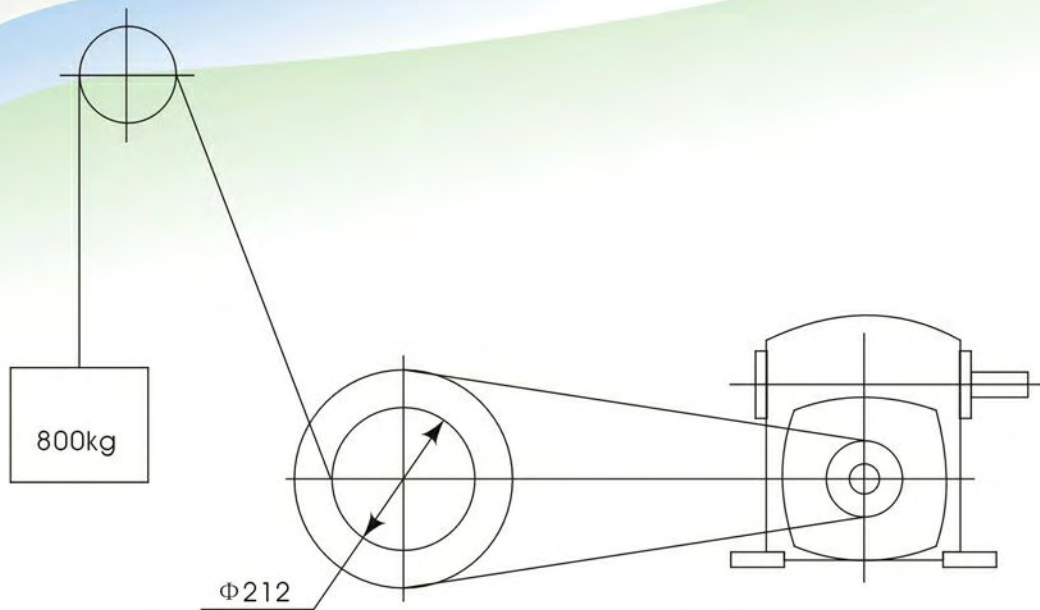

◆ 计算出力轴力矩 T_1

$$T_1 = \frac{800 \times 9.8 \times 0.106}{4 \times 0.92} = 225.862 \text{ N} \cdot \text{M}$$

◆ 计算选型用力矩 T

$$T = T_1 \times \alpha_1 \times \alpha_2 = 225.862 \times 1 \times 1.2 = 270.99 \approx 271 \text{ N} \cdot \text{M}$$

◆ 计算入力轴功率 P

$$P = \frac{T \times n_2}{9550 \times u}$$

其中：出力轴转速 $n_2 = \frac{1450}{30} = 48.333 \text{ r/min}$

u 取0.72

$$P = \frac{271 \times 48.333}{9550 \times 0.72} = 1.905 \text{ KW}$$

◆ 选型

依据计算结果和选型原则，从产品说明书中的对应表格中知：

$$p=2.1>1.905\text{kW}$$

$$T=277>271\text{N}\cdot\text{M}$$

最后选取100型 即：WPS100型 速比1：30

※ 安装与使用 ※ Install and Usage

■ 安装注意事项

- ◆ 减速机须安装在平整坚固的底座上，底脚螺栓必须紧固、防震。
- ◆ 原动机-减速机-工作机的各联接轴伸，安装后必须互相准确对准轴线。
- ◆ 减速机输入端及输出端轴伸外径公差尺寸均按h6制作，与之相配的联轴器、皮带轮、链轮等传动件内孔须按合适的公差尺寸配制，避免装配过紧损坏轴承，装配过松影响正常动力传递。
- ◆ 链轮、齿轮等传动件装上轴伸时，应尽量靠近轴承，以减少轴伸弯曲应力。
- ◆ WPD型减速机装配电机时，应在蜗杆头部内孔孔壁及键槽处涂抹黄油，避免装配过紧，防止轴孔日久生锈。

订购使用各类WPD减速机时，若电机重量偏大，应设支撑装置。

■ 使用注意事项

- ◆ 使用前应注意检查减速机型式结构、中心距规格、传动比、输入轴连接方式、输出轴结构、输入轴输出轴轴指向和回转方向等是否符合使用要求。
- ◆ 按照样本上“润滑油的选择使用”中所规定的要求，注入合适的品种牌号润滑油。加油后，旋紧顶部的通气器，拔掉通气器上之小锥塞，减速机方可开始运转。必须选用合适牌号的润滑油，必须控制适宜的加油量，必须按规定要求及时换油，尤其要重视首次使用100小时后的更换新油。
- ◆ 使用过程中发生不正常情况时，应及时停机检查，可参照“故障原因及解决办法”表处理。（减速机的油温最高允许达到95℃，在此温度界限下，只要油温不再上升，可以放心使用）。

※ 润滑油的选择使用
 ※ Choice of lubricant



蜗轮减速机使用前应注入N220~N320 (环境温度-30℃~40℃) 或N320~460 (环境温度40℃~65℃)润滑油至油标中心点上, 并取掉通气器上之小锥塞.首次使用100小时后, 洗净内部换上新油, 以后每2500小时换油一次。

Before operating worm gear speed reducer, add N220 ~ N320(Ambient temperature-30℃~40℃)、N320~N460(Ambient temperature 40℃~65℃)lubrication oil upto the center line of the oil guage. In the mean while, remove the small screw of the air-vent. After having worked for 100 hours for the first time, must clear the inside and change the lubrication oil in it, hre after once every 2500 hours.

■ 减速机在使用时,可按下表选用润滑油.

Lubricants for a reducer used in foreign countries can be chosen from the table blow

Worm shaft sped(r/min)		Lubricant	Operating Position Worm Shaft, Upper Worm Shaft Vertical	Oprating Position Worm Shaft, Lower Output Shaft Vertical
OVER	UPTO			
1000	3000	Synthetic oils	PG460	PG220
	1000			PG460
2000	3000	Mineral oils	ISOVG460	ISO VG200
750	2000			ISO VG320
250	750			ISO VG460
	250			ISO VG680

Ambient Temperature	Lubricant			Mobil		Union 76 Div . Union OIL C o. of CA	AGMA
15-60℃ -9-16℃	Mineral Oils	Spartan EP220	Regal Oil R&D 320	DTE LIL BB	Shell Omala Oil 220	Union Turbine Oil 220	5
	Compounded Oils	SPARAN EP320	631-Honor Cylinder Oil	Mobil 600W Cylinder Oil	Shell Omala Oil 320	Union Steaval A	7
	Extreme Pressure	SPARTAN EP460	Meropa 460	Mobil Gears 634	Shell Omala Oil 460	Union NL Lube 7EP	7EP
50-125℃ 10-52℃	Mineral Oils	SPARTAN EP320	Regal Oil 320	DTE OIL AA	Shell Omala Oil 320	Union turbine Oil 320	6
	Compounded Oisl	SPARTAN EP460	642-650T Cylinder Oil	Mobil 600W Super cylinder oil	Shell Omala Oil 460	Union Worm Gear Lube 140	8
	Extreme Pressure	SPARTAN EP680	Meropa 680	Mobil Gears 636	Shell Omala Oil 660	Union NL Lube 8EP	8EP

After the first 100 hours If operation: drain unit and flush winh ligh oil,refill.

Every 2500 hours If operation: drain;flush and refill.

※ **故障原因及解决办法**

※ **Solutions and Reasons for the General Faults**

故障情况	故障原因	解决办法
过热	原动机、减速机、工作台连接不当	调整至适当位置，使三者相联轴线同轴
	超负荷运转	适当调整负荷
	油封过度磨擦	在油封唇口处滴润滑油
	润滑油过多或过少	按油标指示点调整油量
	润滑油杂质多或润滑性差	更换合适新油
振动	原动机、减速机、工作台固定不良,连接不当	查出固定不良部位，正确固紧
	蜗轮副齿部磨耗或损伤	更换蜗轮副
	轴承磨损	更换轴承
	螺栓松脱	固紧螺栓
杂音	轴承损伤或间隙过大	更换轴承
	蜗轮副啮合不良	修整齿面或更换蜗轮副
	润滑油不足	按油标指示点补加润滑油
	机体内有异物	倒净润滑油带出异物，重加清洁润滑油
漏油	油封唇口磨损	更换油封
	油封档轴颈磨损	更换输出轴或输入轴
	油量过多	按油标指示点调整油量
	放油螺塞未旋紧	螺纹处加密封胶，旋紧螺塞
	油标破损	更换油标
蜗轮副齿面磨损过快	超负荷运转	调整至适当负荷
	润滑油不符合要求	更换合适的润滑油
	润滑油不足	按油标指示点加足润滑油
	未按规定适时换油，润滑油劣化	按规定要求适时换油
	运转温度过高	1.按“过热”故障处理 2.采取合适措施，降低环境温度